

# Mercury™ MP1502 Controller

## Installation and Specifications

PLT-07611, A.2  
October 2024

## Copyright

© 2024 HID Global Corporation/ASSA ABLOY AB. All rights reserved.

This document may not be reproduced, disseminated or republished in any form without the prior written permission of HID Global Corporation.

## Trademarks

HID GLOBAL, HID, the HID Brick logo, and Mercury are trademarks or registered trademarks of HID Global, ASSA ABLOY AB, or its affiliate(s) in the US and other countries and may not be used without permission. All other trademarks, service marks, and product or service names are trademarks or registered trademarks of their respective owners.

## Contacts

For technical support, please visit: <https://support.hidglobal.com>.

## What's new

Date	Description	Revision
October 2024	Minor update to bulk erase configuration memory. Changed backup battery model from BR/CR 2330 to BR/CR 2032.	A.2

A complete list of revisions is available in [Revision history](#).

# Section 01

Overview

## 1.1 MP1502 intelligent controller with two reader interfaces

The MP1502 intelligent controller provides decision making, event reporting, and database storage for the Mercury hardware platform. Two reader interfaces provide control for two physical barriers.

Host communication is via the on-board 10-BaseT/100Base-TX Ethernet port, or the Micro USB port (2.0) with an optional Micro USB to Ethernet adapter.

Each reader port can accommodate a reader that uses TTL (D1/D0, Clock/Data), F/2F (standard or supervised), or 2-wire RS-485 device signaling (OSDP reader for example), and also provides tri-state LED control and buzzer control (one wire LED mode only).

Four Form-C relay outputs can be used for door strike control or alarm signaling.

Eight inputs are provided that can be used for monitoring the door contacts, exit push buttons, and alarm contacts. Input circuits can be configured as unsupervised or supervised.

The MP1502 requires 12 to 24 V DC for power.

## 1.2 MP1502 hardware

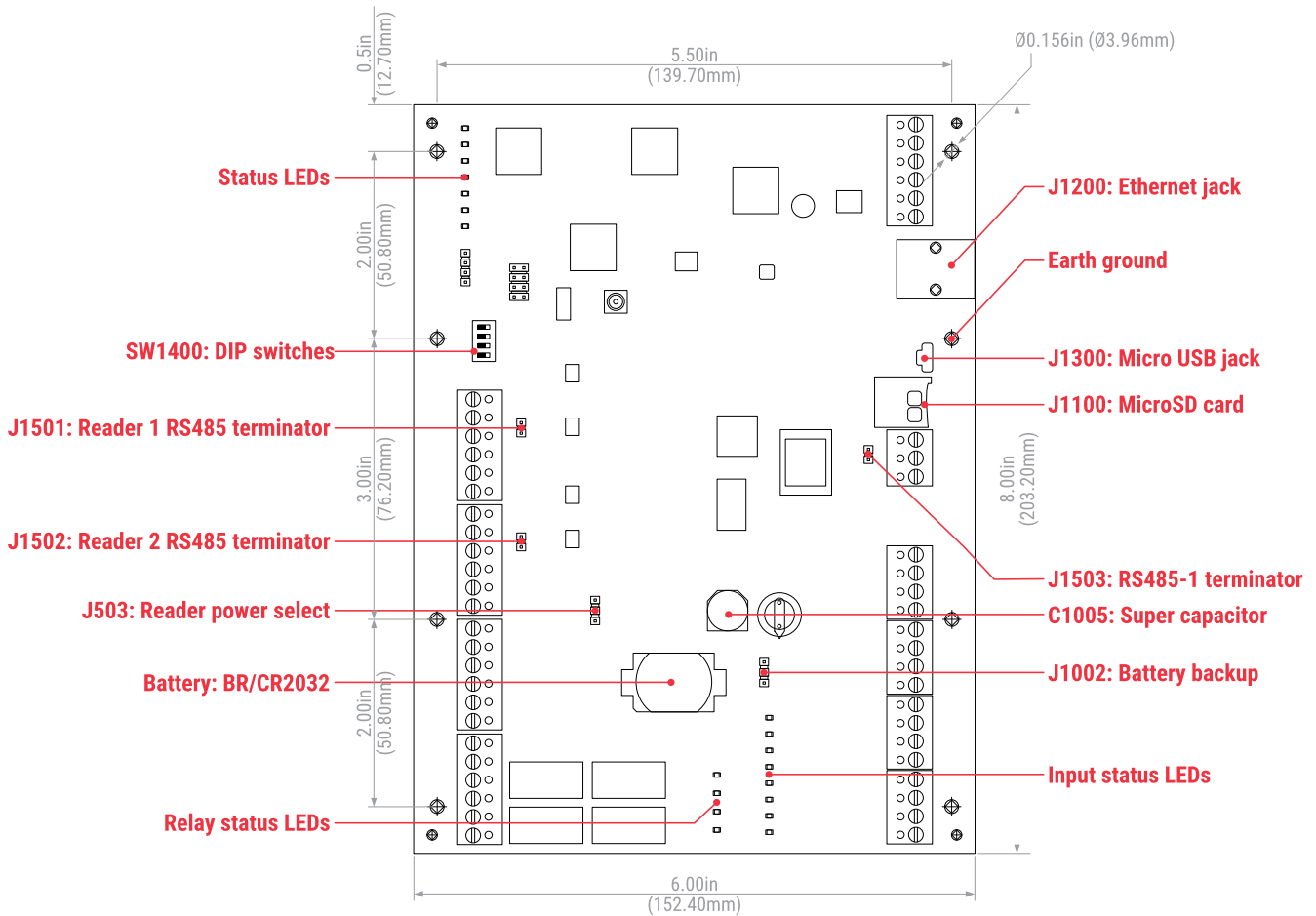

# Section 02

MP1502 wiring and setup

## 2.1 MP1502 connections

<b>TB300-1</b>	GND	Power fault input
<b>TB300-2</b>	FLT	
<b>TB300-3</b>	GND	Cabinet tamper input
<b>TB300-4</b>	TMP	
<b>TB300-5</b>	GND	Power input
<b>TB300-6</b>	VIN: 12 to 24 V DC	

<b>TB1500</b>	N/A	Not used
---------------	-----	----------

<b>TB1501-1</b>	GND	SIO port (2-wire RS-485)
<b>TB1502-2</b>	TR- (B) <sup>1</sup>	
<b>TB1503-3</b>	TR+ (A) <sup>1</sup>	

<b>TB1703-1</b>	IN2	Input 2
<b>TB1703-2</b>	IN2	
<b>TB1703-3</b>	IN1	Input 1
<b>TB1703-4</b>	IN1	

<b>TB1701-1</b>	IN4	Input 4
<b>TB1701-2</b>	IN4	
<b>TB1701-3</b>	IN3	Input 3
<b>TB1701-4</b>	IN3	

<b>TB1705-1</b>	IN6	Input 6
<b>TB1705-2</b>	IN6	
<b>TB1705-3</b>	IN5	Input 5
<b>TB1705-4</b>	IN5	

<b>TB1707-1</b>	IN8	Input 8
<b>TB1707-2</b>	IN8	
<b>TB1707-3</b>	IN7	Input 7
<b>TB1707-4</b>	IN7	

<b>TB1603-1</b>	GND	Reader 1 - Ground
<b>TB1603-2</b>	DAT/DO	Reader 1 - Data/Data 0/TR- (A) <sup>1</sup>
<b>TB1603-3</b>	CLK/D1	Reader 1 - Clock/Data 1/TR+ (B) <sup>1</sup>
<b>TB1603-4</b>	BZR	Reader 1 - Buzzer
<b>TB1603-5</b>	LED	Reader 1 - LED
<b>TB1603-6</b>	VO	Reader power

<b>TB1601-1</b>	GND	Reader 2 - Ground
<b>TB1601-2</b>	DAT/DO	Reader 2 - Data/Data 0/TR- (A) <sup>1</sup>
<b>TB1601-3</b>	CLK/D1	Reader 2 - Clock/Data 1/TR+ (B) <sup>1</sup>
<b>TB1601-4</b>	BZR	Reader 2 - Buzzer
<b>TB1601-5</b>	LED	Reader 2 - LED
<b>TB1601-6</b>	VO	Reader power

<b>TB1800-1</b>	NO	Out 1 - Normally open contact
<b>TB1800-2</b>	C	Out 1 - Common contact
<b>TB1800-3</b>	NC	Out 1 - Normally closed contact

<b>TB1800-4</b>	NO	Out 2 - Normally open contact
<b>TB1800-5</b>	C	Out 2 - Common contact
<b>TB1800-6</b>	NC	Out 2 - Normally closed contact

<b>TB1802-1</b>	NO	Out 3 - Normally open contact
<b>TB1802-2</b>	C	Out 3 - Common contact
<b>TB1802-3</b>	NC	Out 3 - Normally closed contact

<b>TB1802-4</b>	NO	Out 4 - Normally open contact
<b>TB1802-5</b>	C	Out 4 - Common contact
<b>TB1802-6</b>	NC	Out 4 - Normally closed contact

1. Terms (A) and (B) are from the RS-485 standard.

## 2.1.1 Jumpers and jacks

The MP1502 processor hardware interface is configured using jumpers to setup the reader port power and end of line termination.

Jumpers	Set at	Description
<b>J1200</b>	N/A	10-Base-T/100Base-Tx Ethernet connection (Port 0)
<b>J1503</b>	OFF	RS-485 EOL Terminator is OFF
	ON	RS-485 EOL Terminator is ON
<b>J1501</b>	OFF	Reader 1 RS-485 EOL Terminator is OFF (Non-OSDP readers)
	ON	RS-485 EOL Terminator is ON (OSDP readers)
<b>J1502</b>	OFF	Reader 2 RS-485 EOL Terminator is OFF (Non-OSDP readers)
	ON	RS-485 EOL Terminator is ON (OSDP readers)
<b>J1300</b>	N/A	Micro USB port (2.0)
<b>J503</b>	<b>Reader power select. See caution below.</b>	
	12V	12 V DC at reader ports
	PASS	VIN "Pass Through" to reader ports
<b>J1100</b>	N/A	microSD card
<b>J1400-1</b>	N/A	Remote Status LED #1. <sup>1</sup>
<b>J1400-2</b>	N/A	Remote Status LED #2. <sup>1</sup>
<b>J1400-3</b>	N/A	Remote Status LED #3. <sup>1</sup>
<b>J1400-4</b>	N/A	Remote Status LED #4. <sup>1</sup>
<b>J1002</b>	<b>Super capacitor or battery backup real time clock.</b>	
	OFF	Backup battery is OFF.
	ON	Backup battery is ON. Default J1002 link 1 and 2 super capacitor real time clock back up. Link 2 and 3 battery back up. See <b>Memory and real time clock backup battery</b>

1. Observe polarity connection to LED. External current limiting is not required.



**Caution:** Install jumper J503 link 1 and 2 when input voltage (VIN) is greater than 17 V DC for 12 V regulated reader output.



## 2.2 DIP switches

The four switches on S1 DIP switch configure the operating mode of the MP1502 processor. DIP switches are read on power-up except where noted. Pressing reset switch S2 causes the MP1502 to reboot.

1	2	3	4	Definitions
OFF	OFF	OFF	OFF	Normal operating mode.
ON	X	OFF	OFF	After initialization, enable default User Name (admin) and Password (password). The switch is read on the fly, a re-boot is not required. See <b>IT security</b> for additional information.
OFF	ON	OFF	OFF	Use factory default communication parameters.
ON	ON	OFF	OFF	Use OEM default communication parameters. Contact system manufacture for details. See <b>Bulk erase configuration memory</b> .
ON	ON	OFF	OFF	Bulk Erase prompt mode at power up. See <b>Bulk erase configuration memory</b> .
X	X	X	ON	Makes the MP1502 report and function like an LP1502. To be used in situations where the host software has not been updated to support the MP series product line.

**Note:**

- All other switch settings for unassigned and are reserved for future use.
- X = It doesn't matter if the switch is on or off.



**Caution:** In the factory or OEM default modes, downloaded configuration/database is not saved to flash memory.

## 2.3 Factory default communication parameters Interface 1 (NIC1)

<b>Network: static IP address</b>	192.168.0.251
<b>Subnet mask</b>	255.255.0.0
<b>Default gateway</b>	192.168.0.1
<b>DNS server</b>	192.168.0.1
<b>Primary host port</b>	IP server, Data security: TLS if Available, port 3001, communication address: 0
<b>Alternate host port</b>	Disabled

## 2.4 Bulk erase configuration memory

The bulk erase function can be used for the following:

- Erase all configuration and cardholder database (sanitize board, less third party applications).
- Update OEM default parameters after OEM code has been changed.
- Recover from database corruption causing the MP1502 board to continuously reboot.

**Note:** If clearing the memory does not correct the initialization problem, contact Tech Support ([TechSupport@Mercury-Security.com](mailto:TechSupport@Mercury-Security.com)).

### 2.4.1 Bulk erase steps

1. Set SW1400 DIP switches 1 and 2 to **ON**, and 3 and 4 to **OFF**.
2. Apply power to the MP1502 board. LED 1 will flash during panel boot up.
3. After bootup is complete, LEDs 1 and 2, and LEDs 3 and 4 start flashing back and forth alternately at a rate of 0.5 seconds. Within 10 seconds of this beginning, change DIP switch 1 to **OFF**.
4. When complete, only LEDs 1 and 4 will flash for about three seconds.
5. The MP1502 board will restart the boot process and be available at the default IP address of 192.168.0.251.



**Caution:** Do not remove power during the bulk erase process.

## 2.5 Input power, cabinet tamper and UPS fault input wiring

The MP1502 requires 12 to 24 V DC power. Locate power source as close to the unit as possible.

**Caution:**

- Connect power with minimum of 18 AWG wire. Connect the GND signal to earth ground in ONE LOCATION within the system! Multiple earth ground connections may cause ground loop problems and is not advised.
- Observe POLARITY on 12 to 24 V DC input!

There are two dedicated inputs for cabinet tamper and UPS fault monitoring. Normal (safe) condition is a closed contact. If these inputs are not used, install a jumper wire.

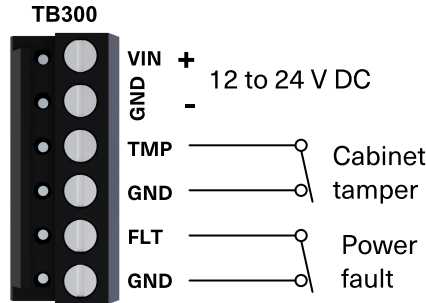

## 2.6 Communication wiring

The MP1502 controller communicates with the host via the on-board Ethernet 10-BaseT/100Base-TX port, and/or the USB port (2.0) with an optional USB to Ethernet adapter.

The serial I/O device communication port (TB1501) is a 2-wire RS-485 interface which can be used to connect additional I/O panels. The interface allows multi-drop communication on a single bus of up to 4,000 feet (1,219 m). Use 1-twisted pair with drain wire and shield, 120Ω impedance, 24 AWG, 4,000 feet. (1,219 m) maximum for communication.

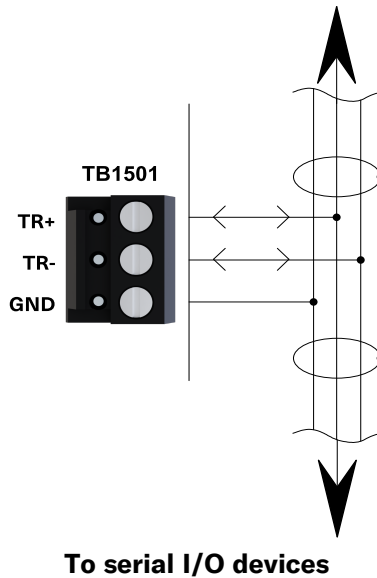

**Caution:** 120Ω end-of-line termination should be added **ONLY** at each end of the RS-485 bus. If the MP1502 is at one end of the RS-485 bus, jumper J1503 can be installed for termination.

## 2.7 Reader wiring

Each reader port supports a reader with TTL (D1/D0, Clock/Data), F/2F (standard or supervised) or 2-wire RS-485 signaling (OSDP reader for example). Power to the readers is selectable: 12 V DC, or power is passed-through (PASS) from the input voltage of the MP1502 (TB300-VIN), 600 mA maximum per reader port. Readers that require different voltage or have high current requirements must be powered separately. Refer to the reader manufacture specifications for cabling requirements. In the 2-wire LED mode the buzzer output is used to drive the second LED. Reader port configuration is set via the host software.



To fully utilize each reader port:

- TTL signaling requires a 6-conductor cable (18 AWG).
- F/2F signaling requires a 4-conductor cable.
- RS-485 signaling requires two 2-conductor cables. Use one cable for power (18 AWG) and one cable for communication (24 AWG, with drain wire and shield).

**Note:** Data 0 and Data 1 wires for Wiegand may be reused for OSDP. However, standard Wiegand cable may not meet RS-485 twisted pair recommendations. The reuse of cable works best on shorter cable lengths at lower data rates.

**Important:** Failure to correctly set the OSDP jumper settings can cause communication issues

### J503 – Reader power select

12V PASS	Reader power
	12 V DC is available on reader ports (VIN > 17 V DC)
	VIN power is "passed through" to reader ports



**Caution:** For 12 V regulated reader output install jumper J501 link 1 and 2 and ensure that the input voltage is greater than 17 V.

**Note:**

- With jumper J503 Link 1 and 2 fitted the reader output can be regulated or pass-through automatically depending on the input voltage:
  - VIN 26.4 V to 17 V = 12 V Output
  - VIN 17 V to 14.5 V = Output OFF
  - VIN 14.5 V to 10.8 V = Pass-through
- Install jumper J503 link 2 and 3 for pass-through from 26.4 V to 10.8 V.
- Ensure the pass-through voltage does not exceed reader maximum operating voltage.

Input power	Reader power select	Reader output
24 V DC	Pass-through	24 V DC
24 V DC	12 V PASS	12 V DC
12 V DC	Pass-through	12 V DC
12 V DC	12 V PASS	12 V DC

## 2.7.1 Reader wiring diagrams

Typical reader 1  
(OSDP installation)

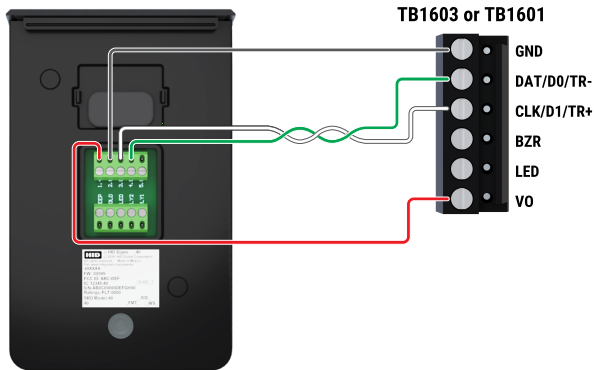

Typical reader 1  
(Wiegand or Clock/Data installation)

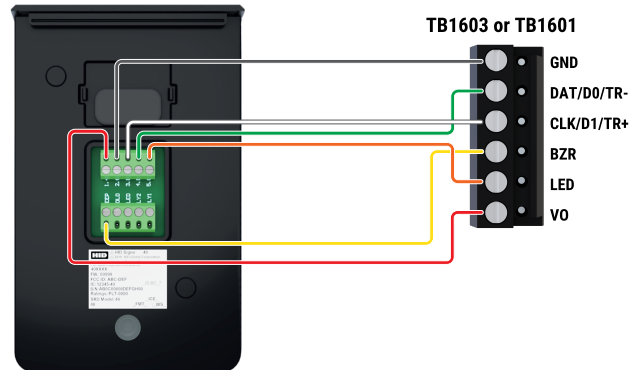

Typical reader 2  
(OSDP installation)

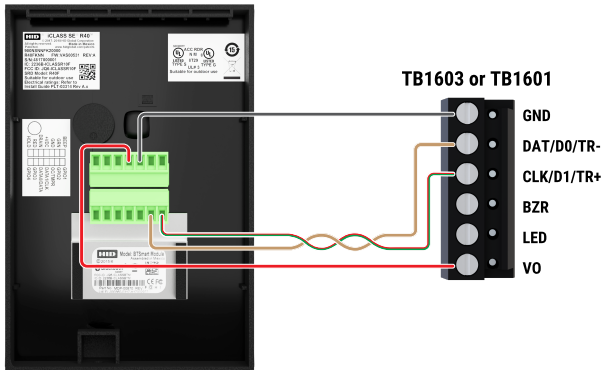

Typical reader 2  
(Wiegand or Clock/Data installation)

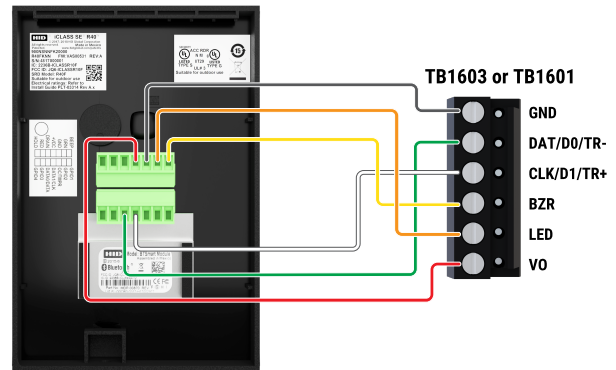

### OSDP Multi drop reader port 1 and 2

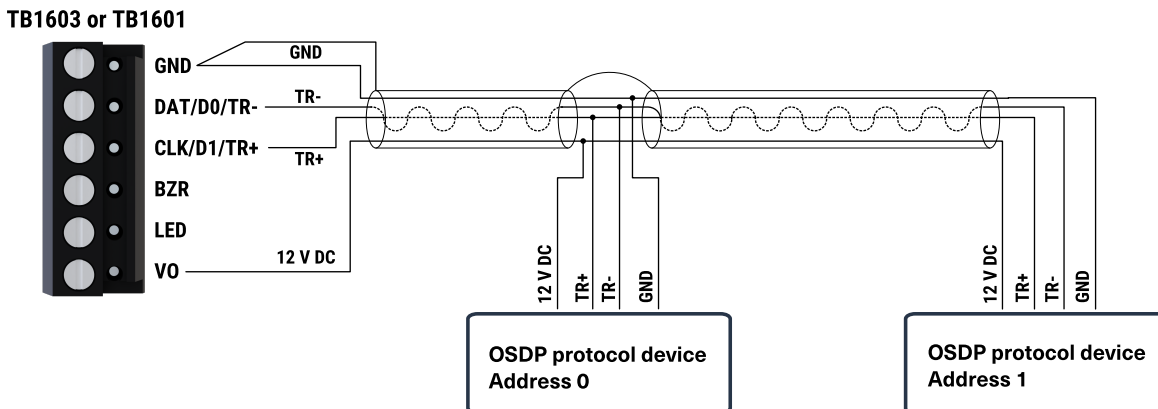

#### Note:

- For OSDP communication a 120Ω end-of-line termination should only be added at each end of the RS-485 bus. If the device is at one end of the RS-485 bus, jumper J1501 (reader port 1) or J1502 (reader port 2) can be installed to enable the termination resistor.
- Refer to the appropriate OSDP installation manual for address and baud rate settings.
- A maximum of two OSDP devices can be connected to a reader port in multi drop installations.

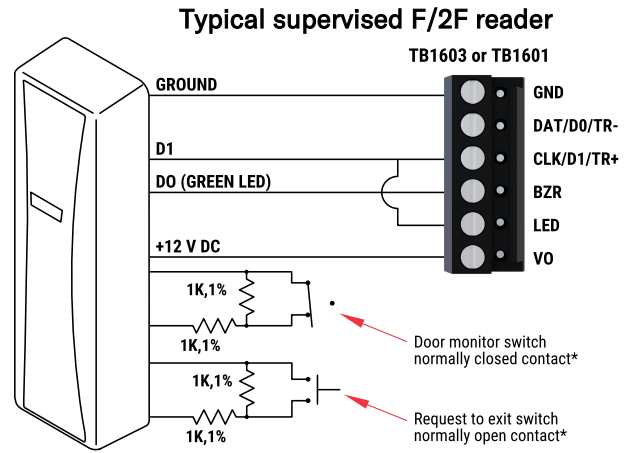
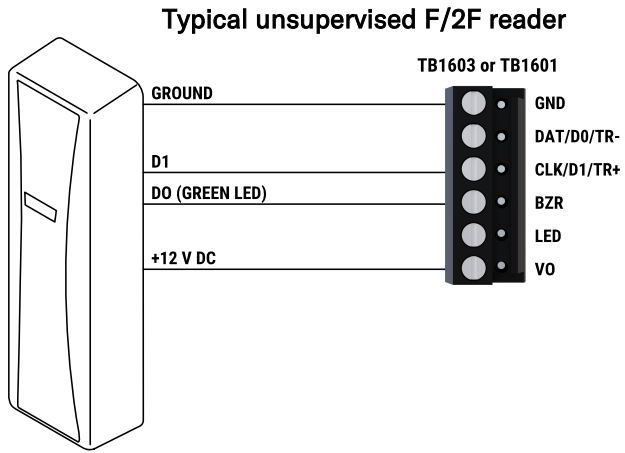

**Jumper D1 to LED on supervised F/2F reader**

\*Inputs on supervised F/2F readers may be unsupervised or supervised (supervised shown).

## 2.8 Input circuit wiring

There are eight inputs that are typically used to monitor door position, request to exit, or alarm contacts. Input circuits can be configured as unsupervised or supervised. When unsupervised, reporting consists of only the open or closed states.

When configured as supervised, the input circuit will report not only open and closed, but also open circuit, shorted, grounded, and foreign voltage.

**Note:** Grounded and foreign voltage states are not a requirement of UL 294 and therefore not verified by UL.

A supervised input circuit requires two resistors be added to the circuit to facilitate proper reporting. The standard supervised circuit requires 1kΩ, 1% resistors and should be located as close to the sensor as possible. Custom end of line (EOL) resistances may be configured via the host software.

The input circuit wiring configurations shown are supported but may not be typical:

**Terminal blocks  
TB1703 through TB1707**

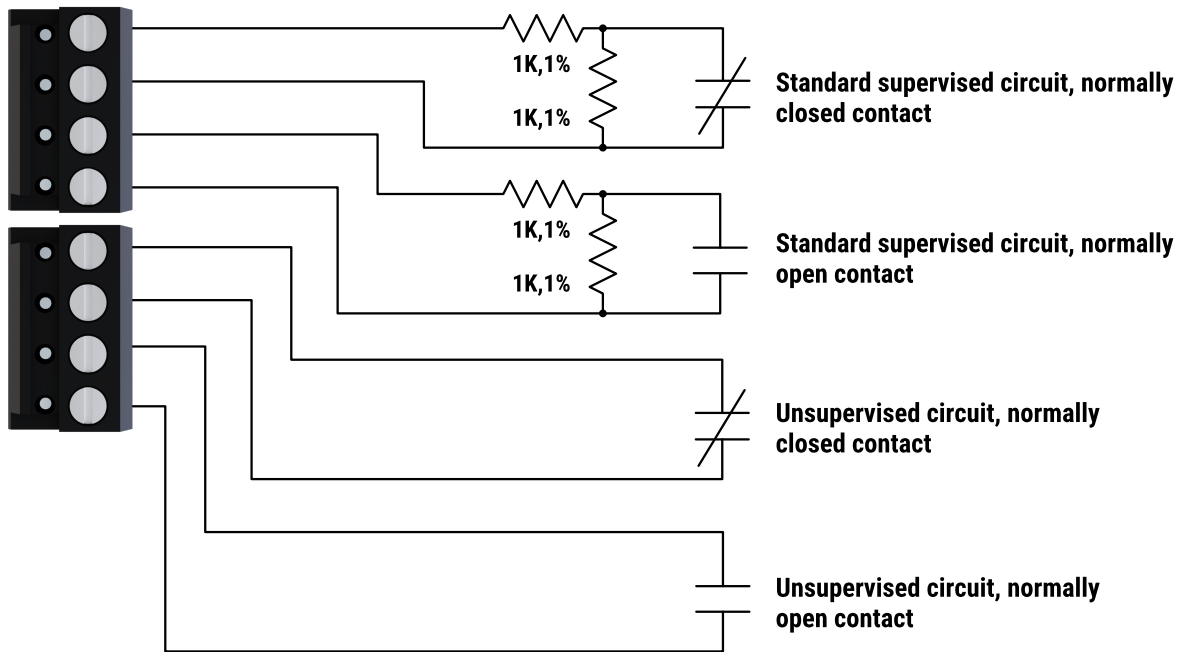

## 2.9 Relay circuit wiring

Four relays with Form-C contacts (dry) are provided for controlling door lock mechanisms or alarm signaling. Each relay has a Common pole (**C**), a Normally Open pole (**NO**) and a Normally Closed pole (**NC**). When controlling the delivery of power to the door strike, the Normally Open and Common poles are typically used. When momentarily removing power to unlock the door, as with a mag lock, the Normally Closed and Common poles are typically used. Check with local building codes for proper egress door installation.

Door lock mechanisms can generate feedback to the relay circuit that can cause damage and premature failure of the relay and affect the operation of the MP1502. It is recommended that a diode is used to protect the relay. Wire should be of sufficient gauge to avoid voltage loss.

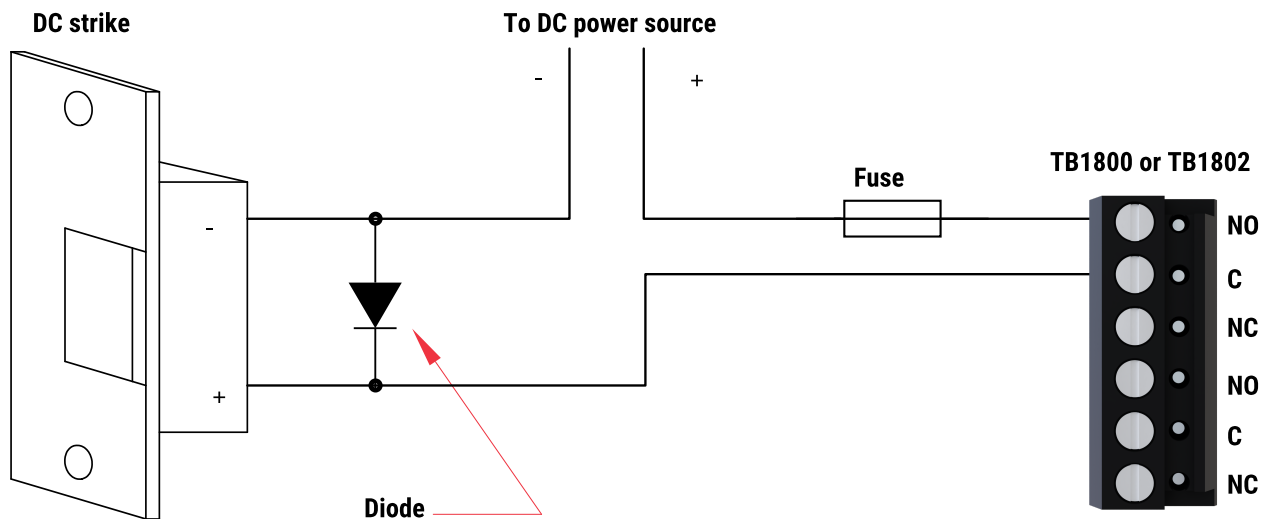

### Diode selection

- Diode current rating: 1x strike current.
- Diode breakdown voltage: 4x strike voltage.
- For 12 V DC or 24 V DC strike, diode 1N4002 (100V/1A) typical.

## 2.10 Memory and real time clock backup battery

The real time clock is backed up by a super capacitor or optional lithium battery when power is interrupted. All other data is stored in non-volatile flash memory.

**Note:** If using the optional lithium battery, this should be replaced annually.

Super capacitor is selected by default J1002 jumper link 1 and 2. To change to battery back up change jumper link to 2 and 3 and fit lithium coin cell.

**Battery type:** BR2032 or CR2032.

**Note:** Data is stored in flash memory to prevent loss of data in the case of power interruption.



## 2.11 Status LEDs

### 2.11.1 Power-up

NIC LED blinks and all other LEDs are off.

### 2.11.2 Initialization

The initialization process has several stages, each stage is represented by a different LED pattern in the following sequence:

- LED 1 is on for about 10 seconds.
- LED 2 is on for 25 seconds.
- LED 3 flashes slowly for 15 seconds.
- LED 3 flashes quickly for 1 second. LED 3 may continue flashing for an additional 60 seconds if the controller firmware is being updated.
- LED 1, LED 2, and LED 3 are off as the application starts.
- LED 4 is then on for 15 seconds indicating a successful initialization.

The amount of time the application takes to initialize depends on the size of the database, but is typically about one second without a card database. Each 10,000 cards will add about two seconds to the application initialization. When LEDs 1, 2, 3, and 4 flash at the same time, data is being read from or written to flash memory, do not cycle power when in this state. If the sequence stops or repeats, perform the bulk erase procedure, see **Bulk erase configuration memory**.

### 2.11.3 Running

After initialization is complete, the LEDs have the following meanings:

LED	Description
1	Off-line / On-line and battery status
	Off-line = 20% ON, On-line = 80% ON
	Double flash if battery is low
2	Host communication activity (Ethernet or Micro USB port)
3	Internal SIO communication activity
4	External SIO communication activity
5	Unassigned
R1	<b>Reader 1:</b> Clock/Data or D1/D0 mode: Flashes when data is received, either input F/2F mode: Flashes when data/acknowledgment is received RS-485 mode: Flashes when transmitting data
R2	<b>Reader 2:</b> Clock/Data or D1/D0 mode: Flashes when data is received, either input F/2F mode: Flashes when data/acknowledgment is received RS-485 mode = Flashes when transmitting data
ETH ACT	D1200 flashes with Ethernet traffic.
YEL	Ethernet speed: OFF = 10Mb/S, ON = 100Mb/S
GRN	OFF = No link, ON = Good link, Flashing = Ethernet activity

<b>LED</b>	<b>Description</b>
<b>IN1</b>	Input IN1 status: OFF = Inactive, ON = Active, Flash = Fault. <sup>1</sup>
<b>IN2</b>	Input IN2 status: OFF = Inactive, ON = Active, Flash = Fault. <sup>1</sup>
<b>IN3</b>	Input IN3 status: OFF = Inactive, ON = Active, Flash = Fault. <sup>1</sup>
<b>IN4</b>	Input IN4 status: OFF = Inactive, ON = Active, Flash = Fault. <sup>1</sup>
<b>IN5</b>	Input IN5 status: OFF = Inactive, ON = Active, Flash = Fault. <sup>1</sup>
<b>IN6</b>	Input IN6 status: OFF = Inactive, ON = Active, Flash = Fault. <sup>1</sup>
<b>IN7</b>	Input IN7 status: OFF = Inactive, ON = Active, Flash = Fault. <sup>1</sup>
<b>IN8</b>	Input IN8 status: OFF = Inactive, ON = Active, Flash = Fault. <sup>1</sup>
<b>OUT1</b>	Relay K1: ON = Energized
<b>OUT2</b>	Relay K2: ON = Energized
<b>OUT3</b>	Relay K3: ON = Energized
<b>OUT4</b>	Relay K4: ON = Energized

1. If this input is defined, every three seconds the LED is pulsed to its opposite state for 0.1 seconds, otherwise, the LED is off.

## 2.12 IT security

Ensure that the MP1502 is installed securely. Create user accounts to the web configuration page using secure passwords.

Ensure all DIP switches are to be in the **OFF** position for the normal operating mode.

The MP1502 is shipped from the factory with a default login account, which is enabled when DIP 1 is moved from **OFF** to **ON** (See **DIP switches**). The default login user name (admin) and password (password) will be available for five minutes once the DIP switch is toggled. It is therefore important that at least one user account is defined, and the DIP switches are set to **OFF** before the MP1502 is commissioned.

Configuring the MP1502 with an IP address that is accessible from the public is **not** recommended.

The following options are available for enhanced network security:

- Disable SNMP.
- Zeroconf discovery.
- The web configuration module.
- Enable data encryption over the host communication port.

# Section 03

## Specifications

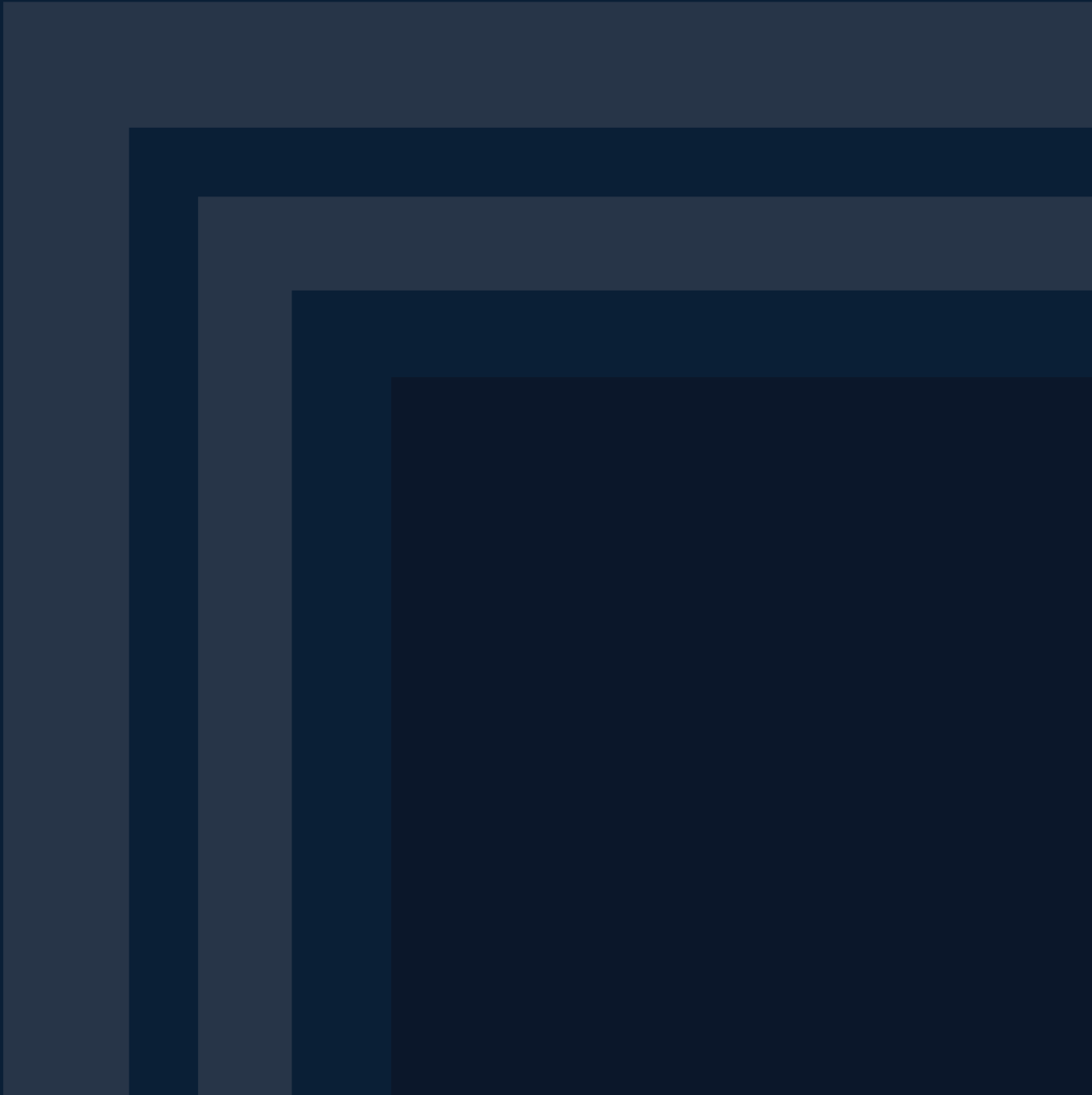

### 3.1 MP1502 controller specifications

The interface is for use in low voltage, Class 2 Circuits only.

The installation of this device must comply with all local fire and electrical codes. Units are to be installed in accordance to NFPA 70. UL verified 12 to 24 V DC. The unit is to be powered with a UL listed UL 294 approved power supply with a class 2 power limited output.

<b>Primary power</b>	12 to 24 V DC $\pm$ 10%, 500 mA maximum (reader and USB ports not included)
<b>Reader ports</b>	600 mA maximum (add 600 mA to primary power current)
<b>Micro USB port</b>	5 V DC, 500 mA maximum (add 270 mA to primary power current) Not evaluated by UL
<b>Memory and clock backup battery</b>	Super capacitor or optional 3 Volt Lithium, type BR2032 or CR2032
<b>microSD card</b>	Format: microSD or microSDHC; 2GB to 8GB
<b>Host communication</b>	Ethernet: 10-BaseT/100Base-TX and Micro USB port (2.0) with optional adapter: pluggable model USB2-OTGE100
<b>Serial I/O device</b>	One each: 2-wire RS-485, 2,400 to 115,200 bps, asynchronous, half-duplex, 1 start bit, 8 data bits, and 1 stop bit
<b>Inputs</b>	Eight unsupervised/supervised, standard EOL: 1k/1k $\Omega$ , 1%, ¼ watt
	Two unsupervised dedicated for cabinet tamper and UPS fault monitoring
<b>Outputs</b>	Four relays, Form-C with dry contacts: Normally open contact (NO) contact: 5 A @ 30 V DC resistive Normally closed contact (NC) contact: 3 A @ 30 V DC resistive
<b>MECHANICAL</b>	
<b>Power (jumper selectable)</b>	12 V DC $\pm$ 10% regulated, 600 mA maximum each reader port (input voltage (VIN) must be greater than 17 V DC)
	or
	12 to 24 V DC $\pm$ 10 % (input voltage (VIN) passed through), 600 mA max per reader port
<b>Data inputs</b>	TTL compatible, F/2F or 2-wire RS-485
<b>RS-485 Mode</b>	9,600 to 115,200 bps, asynchronous, half-duplex, 1 start bit, 8 data bits, and 1 stop bit. Maximum cable length: 2000 feet. (609.6 m)
<b>LED output</b>	TTL levels, high>3 V, low<0.5 V, 5 mA source/sink maximum
<b>Buzzer output</b>	Open collector, 12 V DC open circuit maximum, 40 mA sink maximum

<b>CABLE REQUIREMENTS</b>	
<b>Power</b>	1 twisted pair, 18 AWG (when using local 12 V DC power supply)
<b>Ethernet</b>	CAT-5, minimum
<b>Reader data (TTL)</b>	6-conductor, 18 AWG, 500 feet (152 m) maximum
<b>Reader data (F/2F)</b>	4-conductor, 18 AWG, 500 feet (152 m) maximum
<b>Reader data (RS-485)</b>	1 twisted pair, shielded. 24 AWG, 120Ω impedance, 2000 feet (610 m) maximum
<b>Alarm input</b>	1 twisted pair per input, 30Ω maximum
<b>Outputs</b>	As required for the load
<b>ENVIRONMENTAL</b>	
<b>Storage temperature</b>	-55 to +85°C
<b>Operating temperature</b>	0 to +70°C
<b>Humidity</b>	5 to 95% RHNC
<b>MECHANICAL</b>	
<b>Dimension</b>	8 inches (203.2 mm) W x 6 inches (152.4 mm) L x 1 inches (25 mm) H
<b>Weight</b>	9 oz. (255 g) nominal, board only

These specifications are subject to change without notice.

#### **UL294 Performance Levels ULC 60839-11-1 Indoor use**

<b>Feature</b>	<b>Level</b>
<b>Standby Power</b>	I
<b>Endurance</b>	IV
<b>Line Security</b>	I
<b>Destructive Attack</b>	I

The models described in the manual are recognized boards intended to be used with ULC 60839-11-1 enclosures, power supply readers, controllers, I/O boards, and an off premise monitoring station to form a grade 2 or higher system. Units may be used in grade 4 system installations provided the full system with this board integrated is verified in the end use application. The boards mentioned have only been evaluated for their specific function for grade 2 requirements. For ULC 60839-11-1 an enclosure with a tamper is required and a reader and power supply is to be verified in the end product, as well as the operations need to be documented in the installation instructions.

## 3.2 Warranty

Mercury Security warrants the product is free from defects in material and workmanship under normal use and service with proper maintenance for one year from the date of factory shipment. Mercury Security assumes no responsibility for products damaged by improper handling or installation. This warranty is limited to the repair or replacement of the defective unit.

There are no expressed warranties other than set forth herein. Mercury Security does not make, nor intends, nor does it authorize any agent or representative to make any other warranties, or implied warranties, and expressly excludes and disclaims all implied warranties of merchantability or fitness for a particular purpose.

Returns must be accompanied by a Return Material Authorization (RMA) number obtained from customer service, and prepaid postage and insurance.

## 3.3 Liability

The Interface should only be used to control exits from areas where an alternative method for exit is available. This product is not intended for, nor is rated for operation in life-critical control applications. Mercury Security is not liable under any circumstances for loss or damage caused by or partially caused by the misapplication or malfunction of the product. Mercury Security's liability does not extend beyond the purchase price of the product.

## 3.4 Regulatory

This device complies with part 15 of the FCC Rules. Operation is subject to the following two conditions: (1) This device may not cause harmful interference, and (2) this device must accept any interference received, including interference that may cause undesired operation.

## Revision history

Date	Description	Revision
October 2024	Minor update to bulk erase configuration memory. Changed backup battery model from BR/CR 2330 to BR/CR 2032.	A.2
August 2024	Updates to <b>2.11 Status LEDs</b>	A.1
May 2024	Initial release.	A.0

