

HID Mercury MR16out-S3 Processor

Installation and Specifications

PLT-05251, A.3
May 2024

Copyright

© 2020 - 2024 HID Global Corporation/ASSA ABLOY AB. All rights reserved.

This document may not be reproduced, disseminated or republished in any form without the prior written permission of HID Global Corporation.

Trademarks

HID GLOBAL, HID, the HID Brick logo, and HID Mercury are trademarks or registered trademarks of HID Global, ASSA ABLOY AB, or its affiliate(s) in the US and other countries and may not be used without permission. All other trademarks, service marks, and product or service names are trademarks or registered trademarks of their respective owners.

Contacts

For technical support, please visit: <https://support.hidglobal.com>.

What's new

Date	Description	Revision
May 2024	UL compliance updates. Updated to new Mercury branding.	A.3

A complete list of revisions is available in [Revision history](#).

Section 01

Overview

1.1 MR16out-S3 processor

The HID® Mercury™ MR16out-S3 processor provides a solution to the OEM system integrator for output control.

The controller has 16 Form-C contact relays for load switching. Additionally, two digital inputs are provided for tamper and power fault status monitoring.

The processor requires 12 to 24 V DC for power.

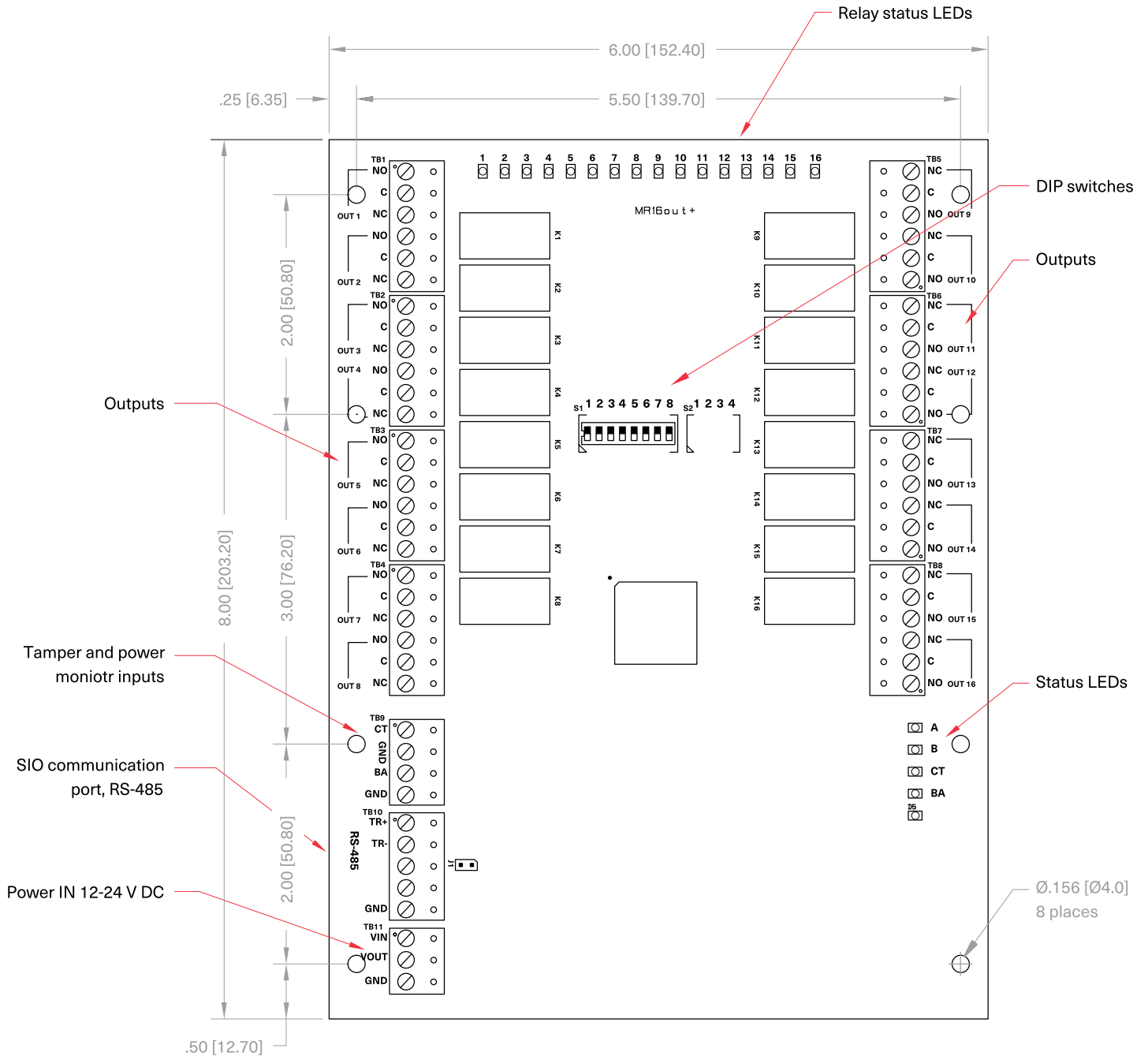

Section 02

MR16out-S3 wiring and setup

2.1 Supplying power to the MR16out-S3

The MR16out-S3 requires 12 to 24 V DC for power on TB11. Locate power source as close to the unit as possible.

Connect power with minimum of 18 AWG wires.

Observe POLARITY on VIN.

The VOUT terminal on TB11 is the same as VIN.

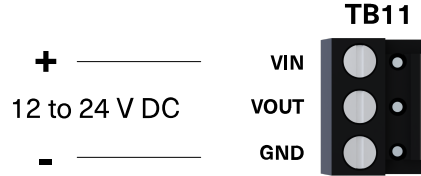

2.2 Communication wiring

The MR16out-S3 communicates with a controller via a 2-wire RS-485 interface. The interface allows multi-drop communication on a single bus of up to 4,000 feet (1,200 m). Use twisted pair (minimum 24 AWG) with shield for the communication line. See **Specifications**.

Install RS-485 termination jumper, J1, on the interface boards at each end of the communication line only.

2-wire RS-485 (only 2-wire RS-485 is supported)

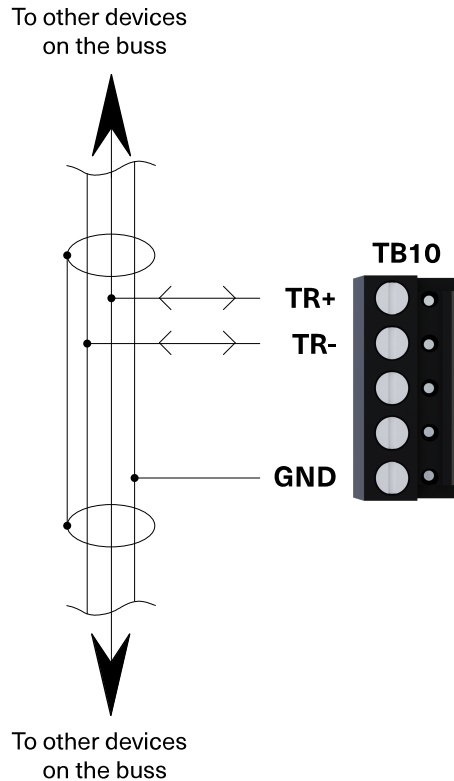

2.3 Inputs for cabinet tamper/power fault

Input CT and input BA are used for monitoring cabinet tamper and power failure with normally closed contacts. These two inputs are for contact closure monitoring only, and do not use EOL resistor(s). If these inputs are not used, install a short piece of wire at the input to indicate a safe condition.

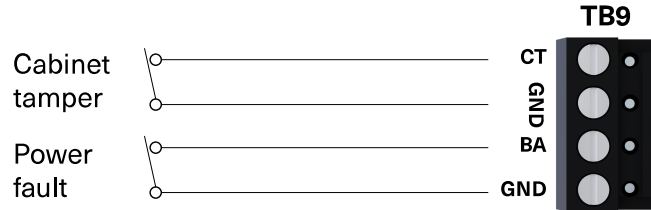

2.4 Relay outputs

The following diagram shows typical use of the relay. Transient clamping must be provided to protect the contacts and to reduce EMI emission. Use sufficiently large wires for the load current to avoid voltage loss.

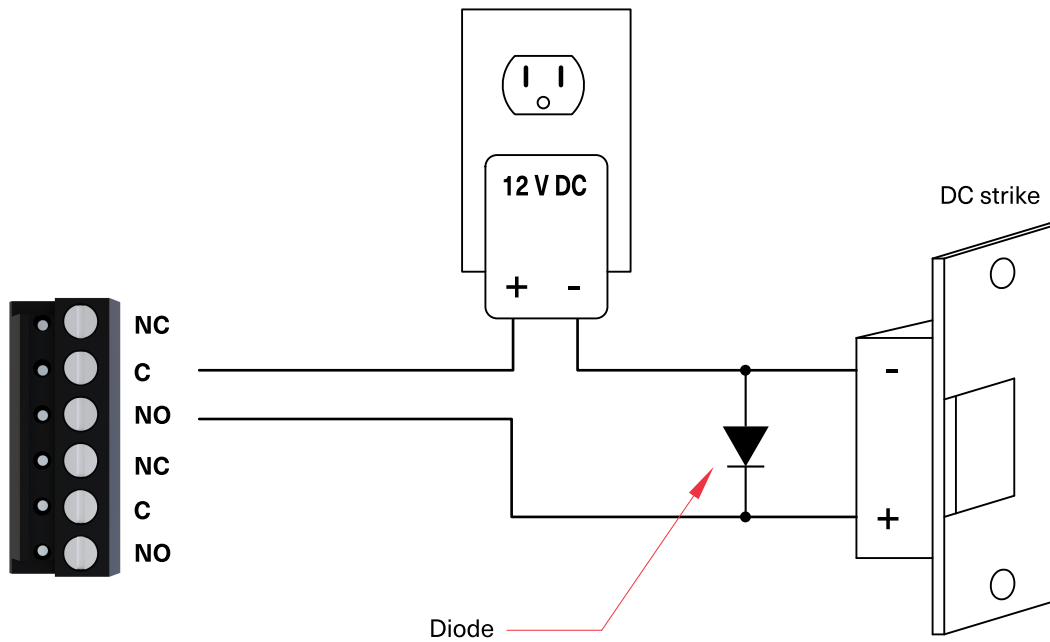

Diode selection

- Diode current rating > 1x strike current.
- Diode break down voltage: 4x strike voltage.
- For 12 V DC or 24 V DC strike, diode 1N4002 (100V/1A) typical.

2.5 DIP switch and jumper usage

- Switches 1 to 5 select the device address. Switches 6 and 7 select the communication baud rate.
- Switch 8 enables encrypted communication. All other configuration settings are set via host software.

S8	S7	S6	S5	S4	S3	S2	S1	Selection
			OFF	OFF	OFF	OFF	OFF	Address 0
			OFF	OFF	OFF	OFF	ON	Address 1
			OFF	OFF	OFF	ON	OFF	Address 2
			OFF	OFF	OFF	ON	ON	Address 3
			OFF	OFF	ON	OFF	OFF	Address 4
			OFF	OFF	ON	OFF	ON	Address 5
			OFF	OFF	ON	ON	OFF	Address 6
			OFF	OFF	ON	ON	ON	Address 7
			OFF	ON	OFF	OFF	OFF	Address 8
			OFF	ON	OFF	OFF	ON	Address 9
			OFF	ON	OFF	ON	OFF	Address 10
			OFF	ON	OFF	ON	ON	Address 11
			OFF	ON	ON	OFF	OFF	Address 12
			OFF	ON	ON	OFF	ON	Address 13
			OFF	ON	ON	ON	OFF	Address 14
			OFF	ON	ON	ON	ON	Address 15
			ON	OFF	OFF	OFF	OFF	Address 16
			ON	OFF	OFF	OFF	ON	Address 17
			ON	OFF	OFF	ON	OFF	Address 18
			ON	OFF	OFF	ON	ON	Address 19
			ON	OFF	ON	OFF	OFF	Address 20
			ON	OFF	ON	OFF	ON	Address 21
			ON	OFF	ON	ON	OFF	Address 22
			ON	OFF	ON	ON	ON	Address 23
			ON	ON	OFF	OFF	OFF	Address 24
			ON	ON	OFF	OFF	ON	Address 25
			ON	ON	OFF	ON	OFF	Address 26
			ON	ON	OFF	ON	ON	Address 27
			ON	ON	ON	OFF	OFF	Address 28
			ON	ON	ON	OFF	ON	Address 29

S8	S7	S6	S5	S4	S3	S2	S1	Selection
			ON	ON	ON	ON	OFF	Address 30
			ON	ON	ON	ON	ON	Address 31
	OFF	OFF						115,200 BPS ¹
	OFF	ON						9,600 BPS
	ON	OFF						19,200 BPS
	ON	ON						38,400 BPS
OFF								Encrypted communication not required ²
ON								Encrypted communication required ²

1. Firmware revisions prior to 1.30.1, this setting is 2,400 BPS.
2. Firmware revisions prior to 1.30.1, SW8 is not defined. Set to the **OFF** position.

2.5.1 Jumper

Jumper	Description
J1	RS-485 termination, install in first and last units only.

Note: All other jumpers are for factory use only.

2.6 Status LEDs

2.6.1 Power-up

All LEDs are OFF.

2.6.2 Initialization

Once power is applied, initialization of the module begins.

When initialization is completed, LEDs A, B, CT, and BA are briefly sequenced ON then OFF.

2.6.3 Run time

After the above sequence, the LEDs have the following meanings:

LED	Description
A LED	Off-line: 1 sec rate, 20% ON
	On-line: Non-encrypted communication: 1 sec rate, 80% ON
	Encrypted communication: .1 sec ON, .1 sec OFF, .1 sec ON, .1 sec OFF, .1 sec ON, .1 sec OFF, .1 sec ON, .3 sec OFF
A LED	Error indication: Waiting for application firmware to be downloaded: .1 sec ON, .1 sec OFF
B LED	SIO communication port status: Indicates communication activity on the SIO communication port.
CT	Cabinet tamper
BA	Power fault
LED 1 through 16	Illuminates when output relay OUT 1 (K1), OUT 2 (K2) is energized and so on.

Section 03

Specifications

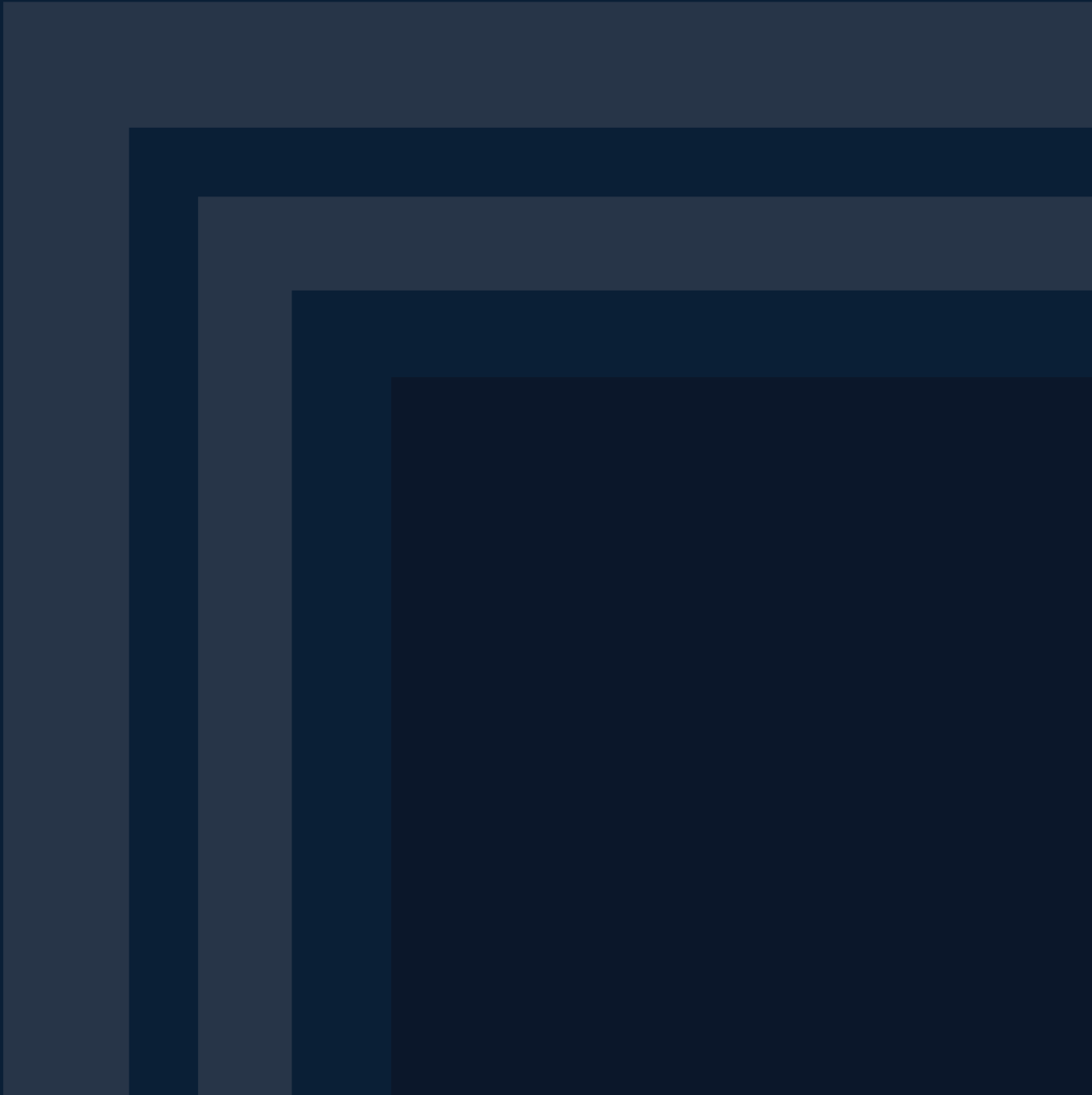

3.1 MR16out-S3 processor specifications

Revision D assembly: The MR16out-S3 is for use in low voltage, class 2 circuits only.

Primary power	12 to 24 V DC \pm 10%, 1100 mA maximum
Relay contacts (sixteen Form-C)	Normally open contact (NO) contact: 5 A @ 30 V DC resistive
	Normally closed contact (NC) contact: 3 A @ 30 V DC resistive
Inputs	2 unsupervised, dedicated for cabinet tamper and UPS fault monitoring
Communication	RS-485, 2-wire. 9600, 19200, 38400, or 115200 bps
MECHANICAL	
Dimension	6 inches (152 mm) W x 8 inches (203 mm) L x 1 inch (25.4 mm) H
Weight	14 oz. (400 gm) nominal
ENVIRONMENTAL	
Storage temperature	-55°C to +85°C
Operating temperature	0°C to +70°C (UL Verified for 0 to 49°C)
Humidity	5% to 95% RHNC

UL 294, 7th edition Performance Levels

Feature	Level
Standby Power	I
Endurance	IV
Line Security	I
Destructive Attack	I

These specifications are subject to change without notice.

- For ULC 60839-11-1 compliance, product was evaluated as Access Control Grade Assignment: Grade 2 Suitable for "Indoor dry conditions".
- If readers are used in system setup, readers (Wiegand or OSDP type) and power supplies connected to this system, are to be ULC 60839-11-1 listed for ULC 60839-11-1 compliance.
- For ULC 60839-11-1, the unit shall be installed in an enclosure secured with a tamper switch.
- For ULC 60839-11-1, the PCB mentioned may be utilized to form a Grade 2 system when there is a compatible grade 2 controller with monitoring and the above items are provided.
- For UL 294 compliance, units are to be powered via a UL 294 power supply with a class 2 power limited output.
- For ULC 60839-11-1, the unit was not evaluated for duress functionality, permitted door release time if programmable shall not be less than 3 seconds.
- Units shall be wired in accordance to NFPA70.

3.2 Warranty

Mercury Security warrants the product is free from defects in material and workmanship under normal use and service with proper maintenance for one year from the date of factory shipment. Mercury Security assumes no responsibility for products damaged by improper handling or installation. This warranty is limited to the repair or replacement of the defective unit.

There are no expressed warranties other than set forth herein. Mercury Security does not make, nor intends, nor does it authorize any agent or representative to make any other warranties, or implied warranties, and expressly excludes and disclaims all implied warranties of merchantability or fitness for a particular purpose.

Returns must be accompanied by a Return Material Authorization (RMA) number obtained from customer service, and prepaid postage and insurance.

3.3 Liability

The Interface should only be used to control exits from areas where an alternative method for exit is available. This product is not intended for, nor is rated for operation in life-critical control applications. Mercury Security is not liable under any circumstances for loss or damage caused by or partially caused by the misapplication or malfunction of the product. Mercury Security's liability does not extend beyond the purchase price of the product.

3.4 Regulatory

This device complies with part 15 of the FCC Rules. Operation is subject to the following two conditions: (1) This device may not cause harmful interference, and (2) this device must accept any interference received, including interference that may cause undesired operation.

Revision history

Date	Description	Revision
May 2024	UL compliance updates. Updated to new Mercury branding.	A.3
August 2022	New branding.	A.2
March 2021	Minor update.	A.1
October 2020	Initial release.	A.0

