

# Mercury™

## MR52-S3 Reader Interface

### Installation and Specifications

PLT-05248, A.5  
September 2024

## Copyright

© 2020 - 2024 HID Global Corporation/ASSA ABLOY AB. All rights reserved.

This document may not be reproduced, disseminated or republished in any form without the prior written permission of HID Global Corporation.

## Trademarks

HID GLOBAL, HID, the HID Brick logo, and Mercury are trademarks or registered trademarks of HID Global, ASSA ABLOY AB, or its affiliate(s) in the US and other countries and may not be used without permission. All other trademarks, service marks, and product or service names are trademarks or registered trademarks of their respective owners.

## Contacts

For technical support, please visit: <https://support.hidglobal.com>.

## What's new

Date	Description	Revision
September 2024	Minor edit to <b>2.6 Control output wiring</b> .	A.5

A complete list of revisions is available in [Revision history](#).

# Section 01

Overview

## 1.1 MR52 reader interface

The Mercury MR52 reader interface boards provide a solution to the OEM system integrator for interfacing to TTL (D1/D0, Clock/Data), F/2F, 2-wire RS-485 device and door hardware. The MR52 provides a tristate LED control, and buzzer control.

Six Form-C relay outputs are provided that can be used for strike control or alarm signaling.

Eight inputs are provided that can be used for monitoring the door contact, request to exit push button, and alarm contacts. Input circuits can be configured as unsupervised or supervised.

The MR52 communicates to the controller via a 2-wire RS-485.

For component location see below (some components shown are not present on the MR52).

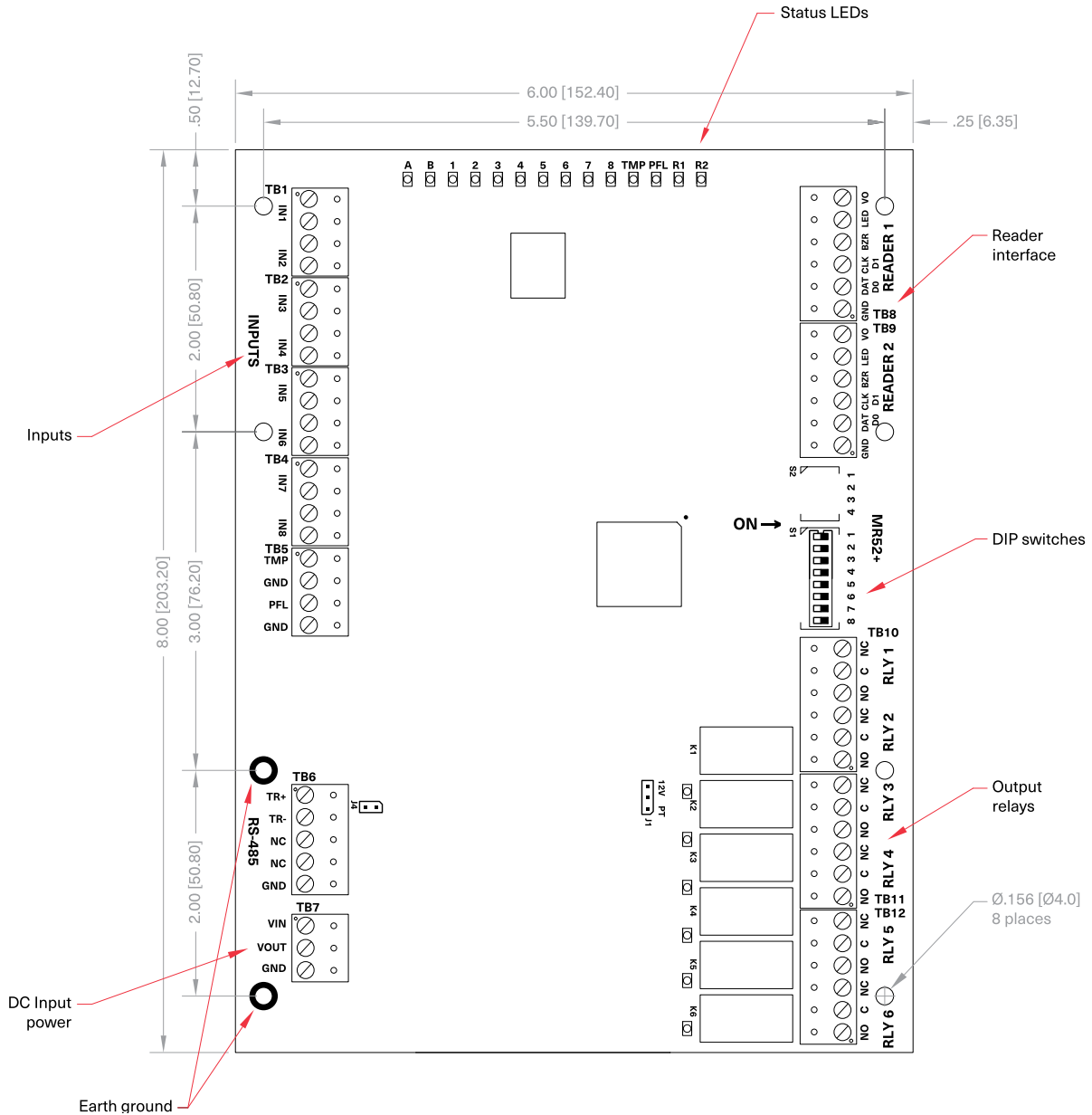

# Section 02

MR52 wiring and setup

## 2.1 Supplying power to the MR52

The MR52 accepts 12 to 24 V DC for power on TB7 (VIN and GND). Locate the power source as close to the MR52 as possible.

**Make power connection with minimum of 18 AWG wires.**

**Observe POLARITY on VIN!**

The VOUT terminal on TB7 is the same as VIN.

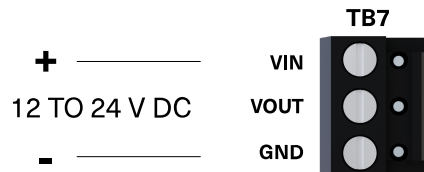

## 2.2 Communication wiring (SIO communication port)

The MR52 communicates with a Mercury intelligent controller (EP2500 for example) via a 2-wire RS-485 interface. The MR52 allows for multi-drop communication on a bus of up to 4,000 feet (1,200 m). Use twisted pair (minimum 24 AWG) with drain wire and shield for communication. See **Specifications**.

Install RS-485 termination jumper, J4, on the interface boards at each end of the communication line only.

### 2-wire RS-485 TB10 (only 2-wire RS-485 is supported)

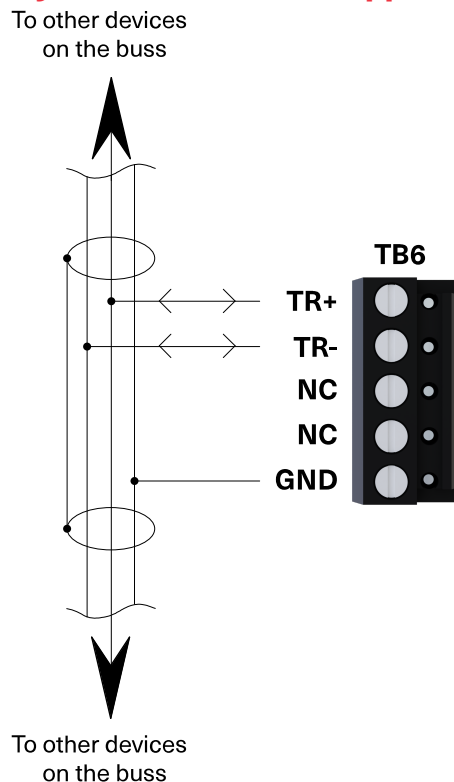

## 2.3 Reader wiring

Each reader port supports a reader with TTL (D1/D0, Clock/Data), F/2F, or 2-wire RS-485 signaling. Power to the reader is selectable: 12 V DC (VIN must be greater than 20 V DC), or power is passed-through (PT) from the input voltage of the MR52 (TB7-VIN), 300 mA maximum per reader port. Readers that require different voltage or have high current requirements must be powered separately. Refer to the reader manufacture specifications for cabling requirements. In the 2-wire LED mode the buzzer output is used to drive the second LED. Reader port configuration is set via the host software.



To fully utilize each reader port:

- TTL signaling requires a 6-conductor cable (18 AWG).
- F/2F signaling requires a 4-conductor cable.
- RS-485 signaling requires two 2-conductor cables. Use one cable for power (18 AWG) and one cable for communication (24 AWG, with drain wire and shield).

**Note:**

- For OSDP cable lengths greater than 200 ft (61 m) or EMF interference, install 120Ω +/- 2Ω resistor across RS-485 termination ends.
- Data 0 and Data 1 wires for Wiegand may be reused for OSDP. However, standard Wiegand cable may not meet RS-485 twisted pair recommendations. The reuse of cable works best on shorter cable lengths at lower data rates.

### J1 – Reader port power select

12V PT	Reader power
	12 V DC is available on reader ports (VIN > 20 V DC)
	VIN power is "Passed Through" to reader ports



**Caution:** If the input voltage to the MR52 is 12 V DC, jumper J1 **MUST** be in the **PT** position.

Input power	Reader power select	Reader output	Notes
24 V DC	Pass-through	24 V DC	
24 V DC	12 V DC	12 V DC	
12 V DC	Pass-through	12 V DC	
12 V DC	12 V DC	0 V DC	<b>Caution:</b> Do not use

2.3.1 Reader wiring diagrams

Typical reader 1  
(OSDP installation)

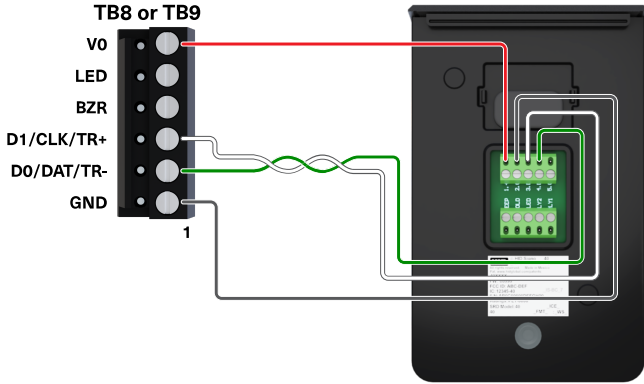

Typical reader 1  
(Wiegand or Clock/Data installation)

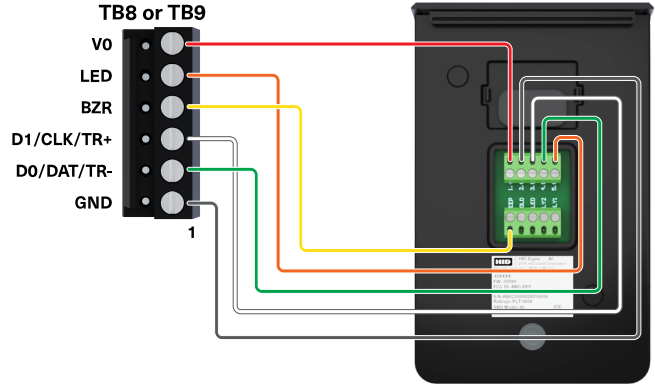

Typical reader 2  
(OSDP installation)

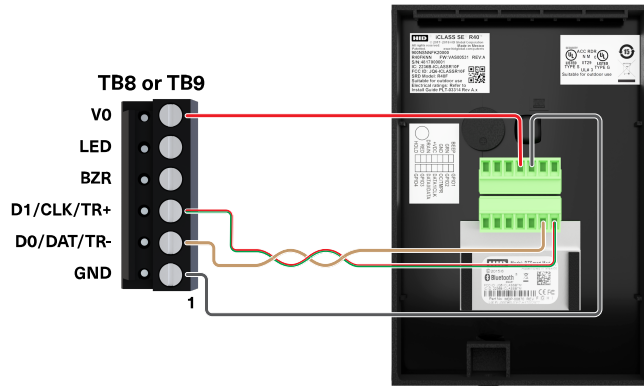

Typical reader 2  
(Wiegand or Clock/Data installation)

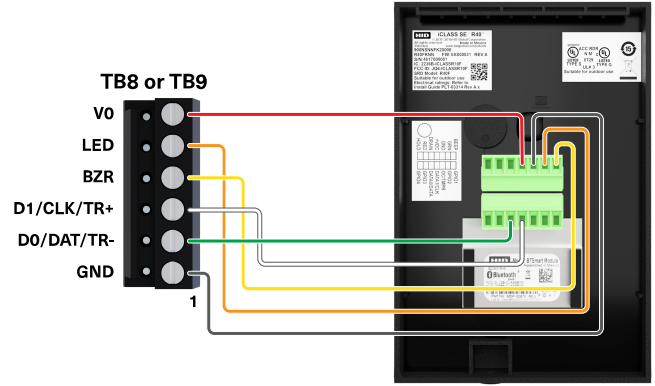

Typical Unsupervised F/2F Reader

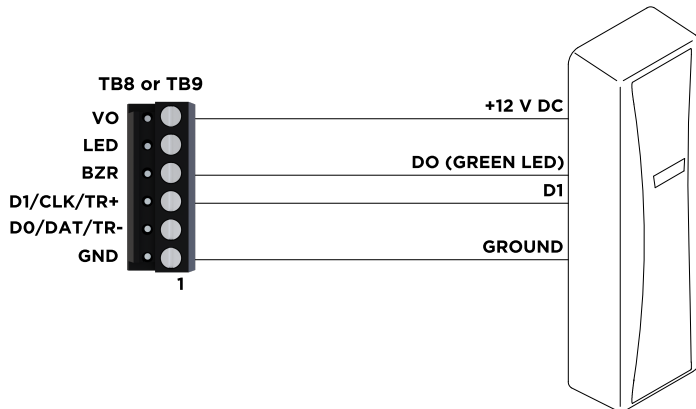

Typical Supervised F/2F Reader

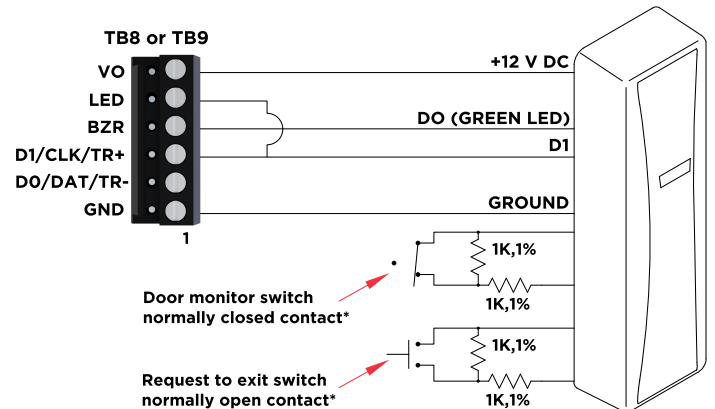

Jumper D1 to LED on supervised F/2F readers

\*Inputs on supervised F/2F readers may be unsupervised or supervised (supervised shown).



## 2.4 Alarm contract wiring

There are eight inputs that are typically used to monitor door position, request to exit or alarm contacts. Input circuits can be configured as:

- Unsupervised alarm (2 states); reporting as open or closed contact.
- Supervised alarm (6 states); reporting as open or closed contact, open circuit, shorted circuit, grounded circuit\*, or foreign voltage\*.

A supervised input circuit requires adding two resistors with value of 1kΩ, 1% to the circuit to facilitate proper reporting and should be located as close to the sensor as possible. Custom end of line (EOL) resistances can be configured via the host software.

\*Grounded and foreign voltage states are not a requirement of UL 294 and therefore not verified by UL.

The input circuit wiring configurations shown are supported but may not be typical:

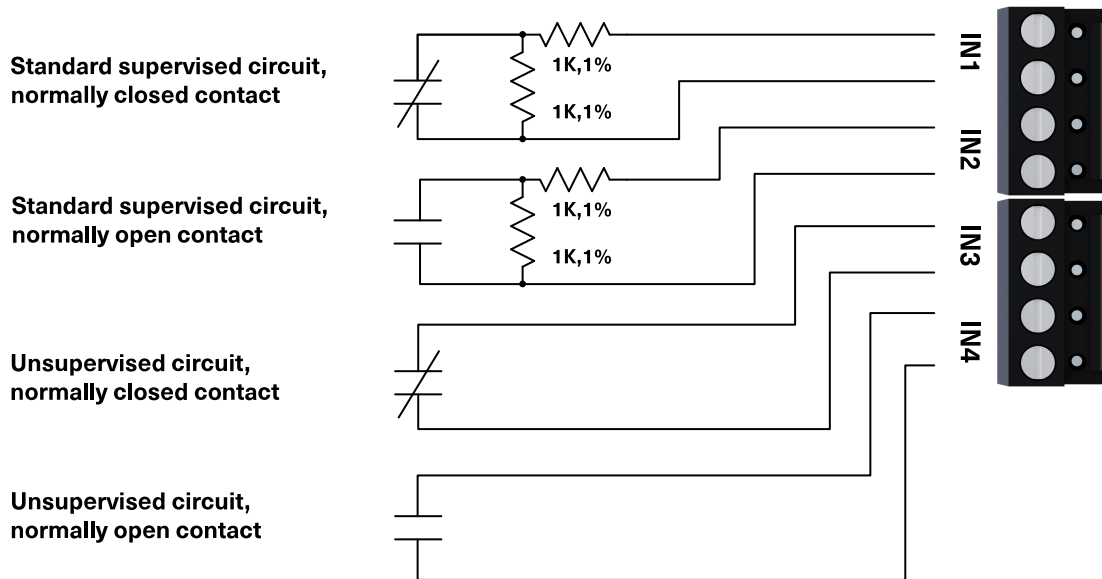

## 2.5 Inputs for cabinet tamper/power fault

Input CT and input BA are used for monitoring cabinet tamper and power failure with normally closed contacts. These two inputs are for contact closure monitoring only, and do not use EOL resistor(s). If these inputs are not used, install a short piece of wire at the input to indicate a safe condition.



## 2.6 Control output wiring

Six Form-C contact relays are provided for controlling door strikes or other devices. Load switching can cause abnormal contact wear and premature contact failure. Switching of inductive loads (strike) also causes EMI (electromagnetic interference) which may interfere with normal operation of other equipment. To minimize premature contact failure and to increase system reliability a contact protection circuit must be used. Locate the protection circuit as close to the load as possible (within 12 inches [30 cm]), as the effectiveness of the circuit will decrease if it is located further away.

Use sufficiently large gauge of wires for the load current to avoid voltage loss.

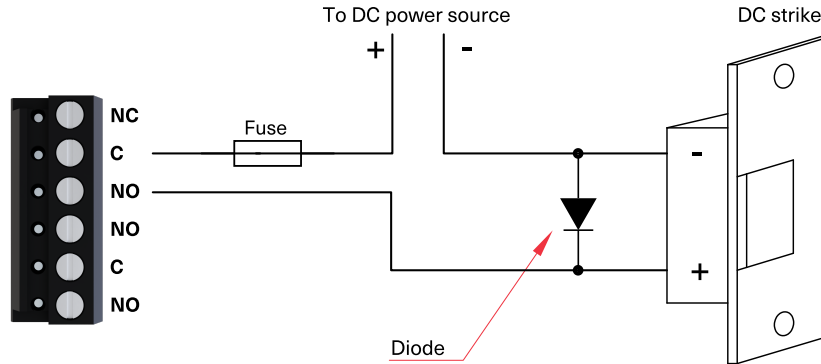

### Diode selection

- Diode current rating > 1x strike current.
- Diode break down voltage: 4x strike voltage.
- For 12 V DC or 24 V DC strike, diode 1N4002 (100V /1A) typical.

## 2.7 Jumpers

Jumper	Description
<b>J1</b>	<b>Reader power select</b>
	12V = 12 V DC at reader ports. <b>See caution below.</b>
	PT = VIN "Passed Through" to reader ports
<b>J4</b>	RS-485 termination, install in first and last units only

**Note:** All other jumpers are for factory use only.



**Caution:** The input power (VIN) must be 20 V DC minimum if the 12 V DC selection is to be used.

## 2.8 Address, baud rate and encryption configuration switch

Switches 1 to 5 select the device address. Switch 6 and 7 select the communication baud rate. Switch 8 enables encrypted communication. All other configuration settings are set via host software.

S8	S7	S6	S5	S4	S3	S2	S1	Selection
			OFF	OFF	OFF	OFF	OFF	Address 0
			OFF	OFF	OFF	OFF	ON	Address 1
			OFF	OFF	OFF	ON	OFF	Address 2
			OFF	OFF	OFF	ON	ON	Address 3
			OFF	OFF	ON	OFF	OFF	Address 4
			OFF	OFF	ON	OFF	ON	Address 5
			OFF	OFF	ON	ON	OFF	Address 6
			OFF	OFF	ON	ON	ON	Address 7
			OFF	ON	OFF	OFF	OFF	Address 8
			OFF	ON	OFF	OFF	ON	Address 9
			OFF	ON	OFF	ON	OFF	Address 10
			OFF	ON	OFF	ON	ON	Address 11
			OFF	ON	ON	OFF	OFF	Address 12
			OFF	ON	ON	OFF	ON	Address 13
			OFF	ON	ON	ON	OFF	Address 14
			OFF	ON	ON	ON	ON	Address 15
			ON	OFF	OFF	OFF	OFF	Address 16
			ON	OFF	OFF	OFF	ON	Address 17
			ON	OFF	OFF	ON	OFF	Address 18
			ON	OFF	OFF	ON	ON	Address 19
			ON	OFF	ON	OFF	OFF	Address 20
			ON	OFF	ON	OFF	ON	Address 21
			ON	OFF	ON	ON	OFF	Address 22
			ON	OFF	ON	ON	ON	Address 23
			ON	ON	OFF	OFF	OFF	Address 24
			ON	ON	OFF	OFF	ON	Address 25
			ON	ON	OFF	ON	OFF	Address 26
			ON	ON	OFF	ON	ON	Address 27
			ON	ON	ON	OFF	OFF	Address 28
			ON	ON	ON	OFF	ON	Address 29
			ON	ON	ON	ON	OFF	Address 30

S8	S7	S6	S5	S4	S3	S2	S1	Selection
			ON	ON	ON	ON	ON	Address 31
	OFF	OFF						115,200 BPS <sup>1</sup>
	OFF	ON						9,600 BPS
	ON	OFF						19,200 BPS
	ON	ON						38,400 BPS
OFF								Encrypted communication not required <sup>2</sup>
ON								Encrypted communication required <sup>2</sup>

1. Firmware revisions prior to 1.38.1, this setting is 2,400 BPS.
2. Firmware revisions prior to 1.38.1, SW8 is not defined. Set to the **OFF** position.

## 2.9 Status LEDs

### 2.9.1 Power-up

All LEDs are OFF.

### 2.9.2 Initialization

Once power is applied, initialization of the module begins.

When initialization is completed, LEDs A through R2 are briefly sequenced ON then OFF.

### 2.9.3 Run time

After the above sequence, the LEDs have the following meanings:

LED	Description
<b>A LED</b> <b>heartbeat and on-line status</b>	Off-line: 1 sec rate, 20% ON
	On-line: Non-encrypted communication: 1 sec rate, 80% ON Encrypted communication: .1 sec ON, .1 sec OFF, .1 sec ON, .1 sec OFF, .1 sec ON, .1 sec OFF, .1 sec ON, .1 sec OFF, .1 sec ON, .3 sec OFF
<b>A LED</b>	Error Indication: Waiting for application firmware to be downloaded: .1 sec ON, .1 sec OFF.
<b>B LED</b>	SIO Communication Port Status: Indicates communication activity on the SIO communication port
<b>1 LED</b>	Input Status: IN1
<b>2 LED</b>	Input Status: IN2
<b>3 LED</b>	Input Status: IN3
<b>4 LED</b>	Input Status: IN4
<b>5 LED</b>	Input Status: IN5
<b>6 LED</b>	Input Status: IN6
<b>7 LED</b>	Input Status: IN7
<b>8 LED</b>	Input Status: IN8
<b>TMP</b>	Cabinet tamper
<b>PFL</b>	Power fault
	Input in the inactive state: OFF (briefly flashes ON every 3 seconds), Input in the active state: ON (briefly flashes OFF every 3 seconds), Input in a trouble state: Rapid Flash.
<b>R1 LED</b>	Reader port 1: Clock/Data Mode: Flashes when data is received, either input D1/D0 Mode: Flashes when data is received, either input RS-485 Mode: Flashes when transmitting data F/2F Mode: Flashes when data/acknowledgment is received
<b>R2 LED</b>	Reader port 2: Clock/Data Mode: Flashes when data is received, either input D1/D0 Mode: Flashes when data is received, either input RS-485 Mode: Flashes when transmitting data F/2F Mode: Flashes when data/acknowledgment is received
<b>K1 through K6 LEDs</b>	Illuminates when output relay RLY 1 (K1) through RLY 6 (K6) is energized. Every three seconds, LEDs A through R2 are pulsed to their opposite state for 0.1 sec.

# Section 03

## Specifications

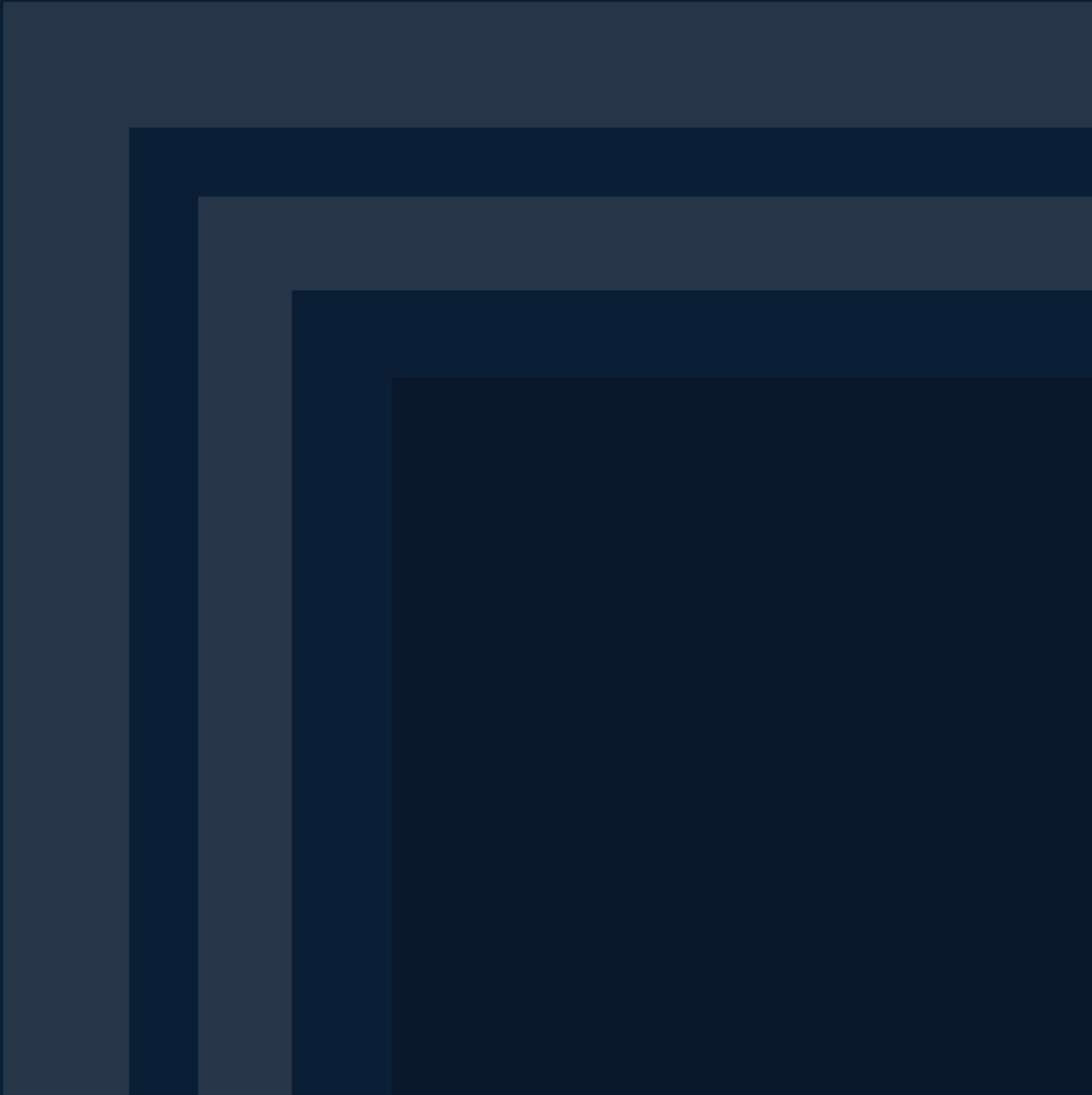

### 3.1 MR52-S3 reader interface specifications

Revision D assembly:

The Interface is for use in low voltage, class 2 circuits only.

The installation of this device must comply with all local fire and electrical codes.

<b>Primary power</b>	12 to 24 V DC $\pm$ 10%, 550 mA maximum (reader current not included)
<b>Outputs</b>	Six Form-C relays: Normally open contact (NO) contact: 5 A @ 30 V DC resistive Normally closed contact (NC) contact: 3 A @ 30 V DC resistive
<b>Inputs</b>	Eight unsupervised/supervised, standard EOL: 1k/1k $\Omega$ , 1%, ¼ watt
	Two unsupervised, dedicated for cabinet tamper and UPS fault monitoring
<b>READER INTERFACE</b>	
<b>Power (jumper selectable)</b>	12 V DC $\pm$ 10% regulated, 300 mA maximum each reader (input voltage (VIN) must be greater than 20 V DC)
	or 12 to 24 V DC $\pm$ 10% (input voltage passed through), 300 mA maximum each reader
<b>Data inputs</b>	TTL compatible, F/2F or 2-wire RS-485
<b>LED output</b>	TTL compatible, high > 3 V, low < 0.5 V, 5 mA source/sink maximum
<b>Buzzer output</b>	Open collector, 12 V DC open circuit maximum, 40 mA sink maximum
<b>Communication</b>	2-wire RS-485: 9600, 19200, 38400 or 115200 bps
<b>CABLE REQUIREMENTS</b>	
<b>Power</b>	1 twisted pair, 18 AWG
<b>RS-485 I/O devices</b>	1 twisted pair with drain wire and shield, 24 AWG, 120 $\Omega$ impedance, 4,000 feet (1,200 m) maximum
<b>Alarm inputs</b>	One twisted pair per input, 30 $\Omega$ maximum
<b>Outputs</b>	As required for the load
<b>Reader data (TTL)</b>	6-conductor, 18 AWG, 500 feet (150 m) maximum
<b>Reader data (F/2F)</b>	4-conductor, 18 AWG, 500 feet (150 m) maximum
<b>Reader data (RS-485)</b>	1 twisted pair with drain wire and shield, 24 AWG, 120 $\Omega$ impedance, 2,000 feet (610 m) maximum
<b>MECHANICAL</b>	
<b>Dimension</b>	6 inches (152 mm) W x 8 inches (203 mm) L x 1 inches (25 mm) H
<b>Weight</b>	11 oz. (312 g) nominal
<b>ENVIRONMENTAL</b>	
<b>Storage temperature</b>	-55 to +85°C
<b>Operating temperature</b>	0 to +70°C
<b>Humidity</b>	5 to 95% RHNC

### UL294, 6<sup>th</sup> edition Performance Levels

Feature	Level
Standby Power	I
Endurance	IV
Line Security	I
Destructive Attack	I

These specifications are subject to change without notice.

## 3.2 Warranty

Mercury Security warrants the product is free from defects in material and workmanship under normal use and service with proper maintenance for one year from the date of factory shipment. Mercury Security assumes no responsibility for products damaged by improper handling or installation. This warranty is limited to the repair or replacement of the defective unit.

There are no expressed warranties other than set forth herein. Mercury Security does not make, nor intends, nor does it authorize any agent or representative to make any other warranties, or implied warranties, and expressly excludes and disclaims all implied warranties of merchantability or fitness for a particular purpose.

Returns must be accompanied by a Return Material Authorization (RMA) number obtained from customer service, and prepaid postage and insurance.

## 3.3 Liability

The Interface should only be used to control exits from areas where an alternative method for exit is available. This product is not intended for, nor is rated for operation in life-critical control applications. Mercury Security is not liable under any circumstances for loss or damage caused by or partially caused by the misapplication or malfunction of the product. Mercury Security's liability does not extend beyond the purchase price of the product.

## 3.4 Regulatory

This device complies with part 15 of the FCC Rules. Operation is subject to the following two conditions: (1) This device may not cause harmful interference, and (2) this device must accept any interference received, including interference that may cause undesired operation.



## Revision history

Date	Description	Revision
September 2024	Minor edit to <b>2.6 Control output wiring</b> .	A.5
May 2024	Updated to new Mercury branding.	A.4
August 2022	New branding.	A.3
June 2021	Minor updates.	A.2
April 2021	Added reader power select table in <b>2.3 Reader wiring</b>	A.1
October 2020	Initial release.	A.0

