

Mercury™ LP1501 Controller

Installation and Specifications

PLT-05243, A.4
August 2024

Copyright

© 2020 - 2024 HID Global Corporation/ASSA ABLOY AB. All rights reserved.

This document may not be reproduced, disseminated or republished in any form without the prior written permission of HID Global Corporation.

Trademarks

HID GLOBAL, HID, the HID Brick logo, and Mercury are trademarks or registered trademarks of HID Global, ASSA ABLOY AB, or its affiliate(s) in the US and other countries and may not be used without permission. All other trademarks, service marks, and product or service names are trademarks or registered trademarks of their respective owners.

Contacts

For technical support, please visit: <https://support.hidglobal.com>.

What's new

Date	Description	Revision
August 2024	Updates to 2.12 Status LEDs	A.4

A complete list of revisions is available in [Revision history](#).

Section 01

Overview

1.1 LP1501 controller with paired interface for one physical barrier

The LP1501 intelligent controller provides decision making, event reporting, and database storage for the Mercury hardware platform. Two reader interfaces configured as paired, or alternate readers provide control for one physical barrier.

Host communication is via the on-board 10-BaseT/100Base-TX Ethernet port.



Caution: For UL compliance, the Power Sourcing Equipment (PSE) such as a PoE or PoE+ enabled network switch and/or PoE or PoE+ power injectors must be UL Listed under UL294B.

Reader port 1 (TB2) can accommodate a reader that uses TTL (D1/DO, Clock/Data), F/2F, or 2-wire RS-485 device signaling (for example an OSDP reader). Reader port 1 also provides tri-state LED control and buzzer control (one wire LED mode only). This port can also use multiple 2-wire RS-485 multi-dropped devices, such as up to two OSDP readers, or up to eight remote serial I/O devices.

Reader port 2 (TB3 and TB4) can accommodate a reader that uses TTL (D1/DO, Clock/Data), or F/2F signaling. Reader port 2 also provides tri-state LED control, and buzzer control (one wire LED mode only). Two Form-C contact relay outputs can be used for door strike control or alarm signaling. The relay contacts are rated at 2 A @ 30 V DC, dry contact configuration. Two inputs are provided that can be used for monitoring the door contact, exit push button, or alarm contact. Input circuits can be configured as unsupervised or supervised.

The LP1501 requires Power over Ethernet (PoE or PoE+) or 12 V DC for power. The LP1501 can be mounted in a 3-gang switch box; a mounting plate is supplied with the unit, or the LP1501 can be mounted in an enclosure; the supplied mounting plate has mounting holes that match the MR50 mounting footprint.

1.2 LP1501 hardware

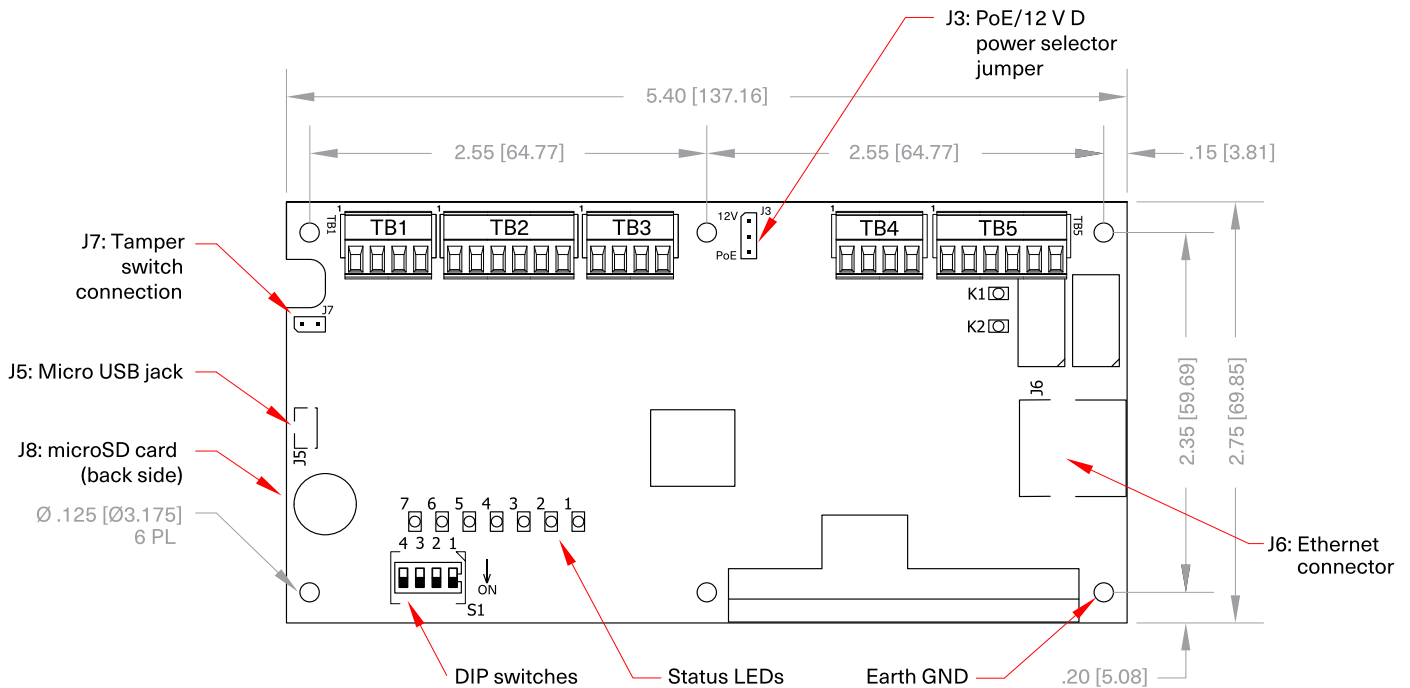

Section 02

LP1501 wiring and setup

2.1 LP1501 connections

TB1-1	IN1	Input 1
TB1-2	IN1	
TB1-3	IN2	Input 2
TB1-4	IN2	

TB2-1	VO	Reader 1 power output – 12 V DC
TB2-2	LED	Reader 1 LED output
TB2-3	BZR	Reader 1 buzzer output
TB2-4	CLK	Reader 1 CLK/Data 1/TR+ (B) ¹
TB2-5	DAT	Reader 1 DAT/Data 0/TR- (A) ¹
TB2-6	GND	Reader 1 ground

TB3-1	LED	Reader 2 LED output
TB3-2	BZR	Reader 2 buzzer output
TB3-3	CLK	Reader 2 CLK/Data 1 input
TB3-4	DAT	Reader 2 DAT/Data 0 input

TB4-1	VO	Auxiliary power output – 12 V DC
TB4-2	GND	Auxiliary power output ground
TB4-3	VIN	Input power – 12 V DC (from local power supply)
TB4-4	GND	Input power ground

TB5-1	NO	Relay K1 – Normally open contact
TB5-2	1-C	Relay K1 – Common contact
TB5-3	NC	Relay K1 – Normally closed contact
TB5-4	NO	Relay K2 – Normally open contact
TB5-5	2-C	Relay K2 – Common contact
TB5-6	NC	Relay K2 – Normally closed contact

1. Terms (A) and (B) are from the RS-485 standard.

2.2 Jumpers

Jumpers	Set at	Description
J1	N/A	Factory use only
J3	PoE	LP1501 powered from the Ethernet connection
	12V	LP1501 powered from a local 12 V DC power source connected to TB4-3 (VIN), TB4-4 (GND)
J4	N/A	Factory use only
J5	N/A	Micro USB port (2.0)
J6	N/A	10-Base-T/100Base-TX Ethernet connection
J7		Cabinet tamper switch input: short = tamper secure
J8	N/A	microSD card

2.3 DIP switches

The four switches on the S1 DIP switch configure the operating mode of the LP1501 processor. DIP switches are read on power-up except where noted.

1	2	3	4	Definitions
OFF	OFF	OFF	OFF	Normal operating mode.
ON	X	X	X	After initialization, enable default User Name (admin) and Password (password). The switch is read on the fly, a re-boot is not required. See 2.13 IT security for additional information.
OFF	ON	X	OFF	Use factory default communication parameters.
ON	ON	X	OFF	Use OEM default communication parameters. Contact system manufacture for details. See 1.1 Bulk erase configuration memory .
ON	ON	OFF	OFF	Bulk erase prompt mode at power up. See 1.1 Bulk erase configuration memory .
X	X	X	ON	Makes the LP1501 report and function like an EP1501. To be used in situations where the host software has not been updated to support the LP series product line.

Note:

- All other switch settings are unassigned and are reserved for future use.
- X = It doesn't matter if the switch is on or off.

2.4 Factory default communication parameters Interface 1 (NIC1)

Network: static IP address	192.168.0.251
Subnet mask	255.255.0.0
Default gateway	192.168.0.1
DNS server	192.168.0.1
Primary host port	IP server, Data security: TLS if Available, port 3001, communication address: 0
Alternate host port	Disabled

2.5 Bulk erase configuration memory

The bulk erase function can be used for the following:

- Erase all configuration and cardholder database (sanitize board, less third party applications).
- Update OEM default parameters after OEM code has been changed.
- Recover from database corruption causing the LP1501 board to continuously reboot.

Note: If clearing the memory does not correct the initialization problem, contact Tech Support (TechSupport@Mercury-Security.com).

2.5.1 Bulk erase steps

1. Set S1 DIP switches 1 and 2 to **ON**, and 3 and 4 to **OFF**.
2. Apply power to the LP1501 board. LED 1 will flash during panel boot up.
3. After bootup is complete, LEDs 1 and 2, and LEDs 3 and 4 start flashing back and forth alternately at a rate of 0.5 seconds. Within 10 seconds of this beginning, change DIP switch 1 to **OFF**.
4. When complete, only LEDs 1 and 4 will flash for about three seconds.
5. The LP1501 board will restart the boot process and be available at the default IP address of 192.168.0.251.



Caution: Do not remove power during the bulk erase process.

2.6 Input power

The LP1501 is powered by one of the following two ways (jumper selected, J3):

- Power is supplied via the Ethernet connection using PoE or PoE+
- Local 12 V DC power supply, TB4-3 (VIN), TB4-4 (GND)

2.7 Reader/serial I/O device wiring

Reader port 1 supports TTL (D1/D0, Clock/Data), F/2F, or 2-wire RS-485 device(s). Reader port 2 supports TTL (D1/D0, Clock/Data), or F/2F. Power to reader port 1 is 12 V DC at 300 mA maximum. The reader connected to reader port 2 may be powered from the 12 V DC auxiliary power supply output; TB4-1 and TB4-2. Readers that require different voltage or have high current requirements should be powered separately. Refer to the reader manufacture specifications for cabling requirements. In the 2-wire LED mode the buzzer output is used to drive the second LED. Reader port configuration is set via the host software.

Reader port 1 can support up to eight 2-wire RS-485 remote serial I/O devices using MSP1 protocol, or up to two OSDP devices. If two OSDP devices are used, reader port 2 will not support a third reader. If only one OSDP device is configured, then reader port 2 is available for a second reader. The maximum cable length is 2000 feet. (610 m). Do not terminate any RS-485 devices connected to reader port 1.

Note:

- For OSDP cable lengths greater than 200 ft (61 m) or EMF interference, install $120\Omega \pm 2\Omega$ resistor across RS-485 termination ends.
- Data 0 and Data 1 wires for Wiegand may be reused for OSDP. However, standard Wiegand cable may not meet RS-485 twisted pair recommendations. The reuse of cable works best on shorter cable lengths at lower data rates.



Caution: When powering remote device(s) from the LP1501, do not exceed the maximum current limit. Cable gauge must also be evaluated. See **Specifications** for details.

2.7.1 Reader wiring diagrams

**Reader port 1, typical reader 1
(OSDP installation)**

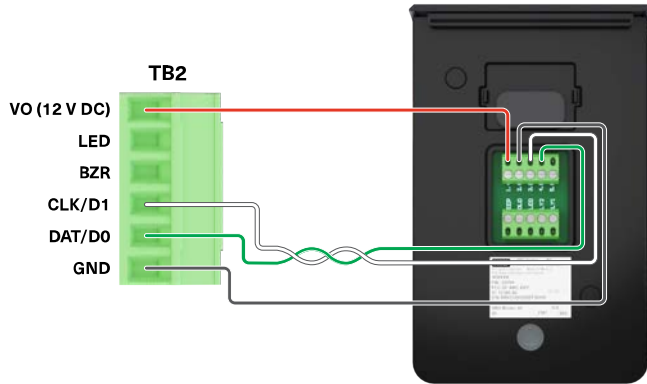

**Reader port 1, typical reader 1
(Wiegand or Clock/Data installation)**

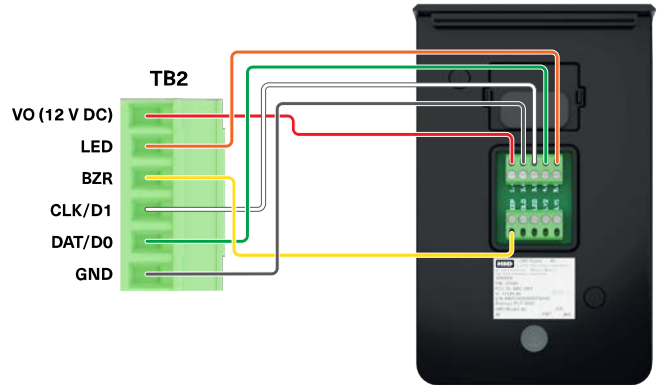

**Reader port 2, typical reader 1
(Wiegand or Clock/Data installation)**

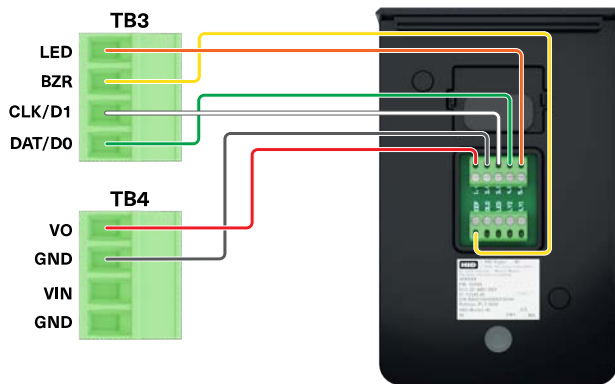

**Reader port 1, typical reader 1
(OSDP installation)**

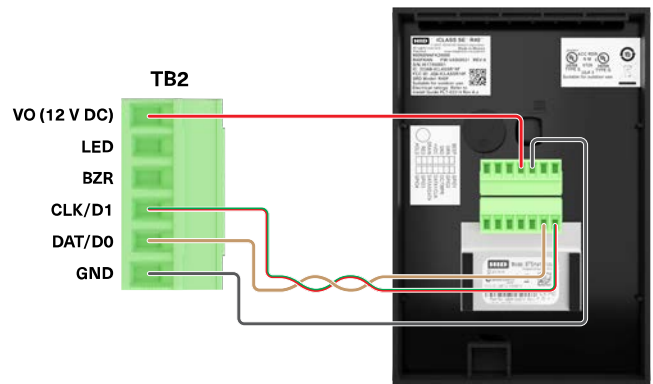

**Reader port 1, typical reader 2
(Wiegand or Clock/Data installation)**

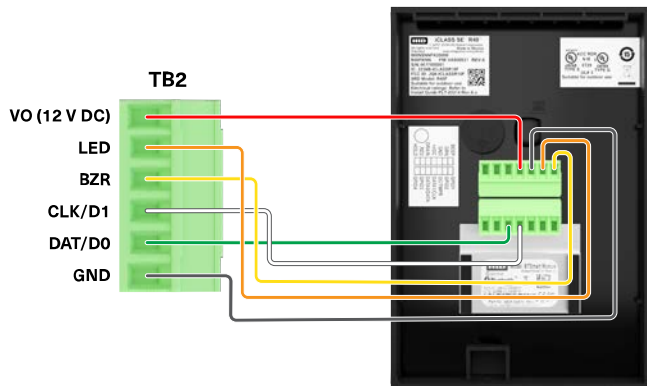

**Reader port 2, typical reader 2
(Wiegand or Clock/Data installation)**

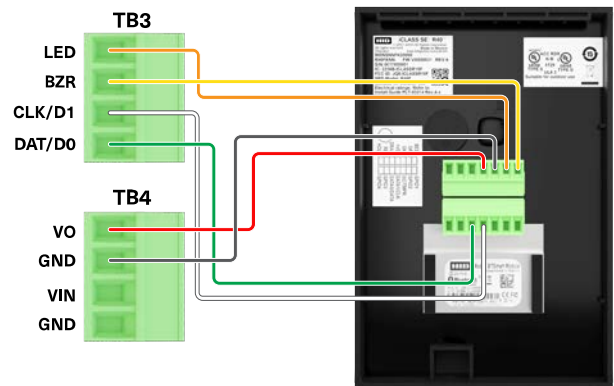

**Reader port 1
Typical unsupervised F/2F reader**

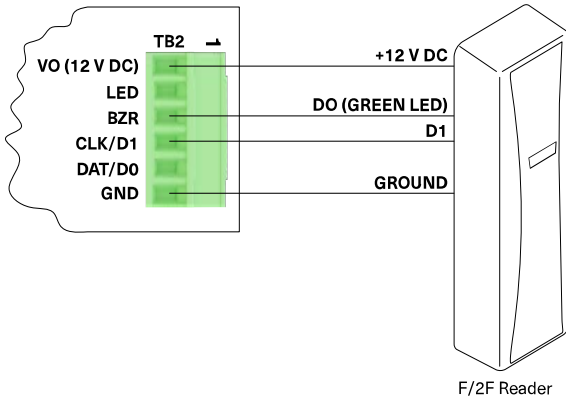

**Reader port 2
Typical unsupervised F/2F reader**

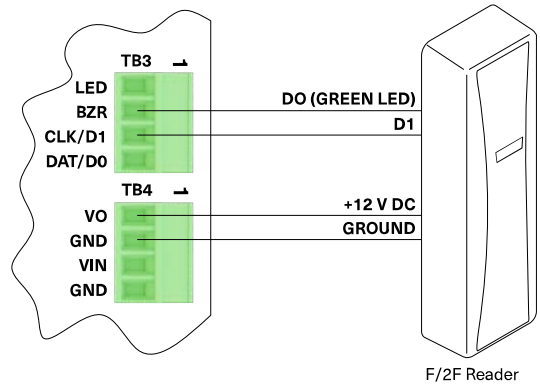

**Reader port 1
Typical supervised F/2F reader**

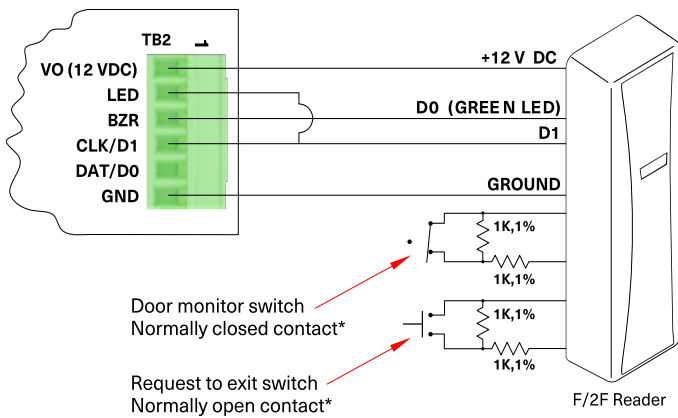

**Reader port 2
Typical supervised F/2F reader**

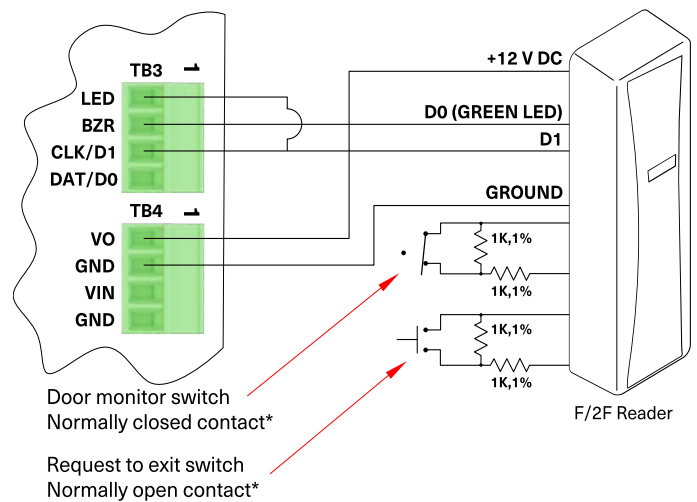

Jumper D1 and LED on supervised F/2F readers

*Inputs on supervised F/2F readers may be unsupervised or supervised (supervised shown).

Reader port 1 - remote serial I/O devices using MSP1 protocol (2-wire RS485)

Refer to the appropriate remote serial I/O device installation manual for address and baud rate settings. Do not terminate any of the devices on the RS-485 multi-drop communication bus. Each remote serial I/O device must be configured with a unique communication address. A maximum of eight remote serial I/O devices can be connected to reader port 1. **Cable shield:** only ground one end.

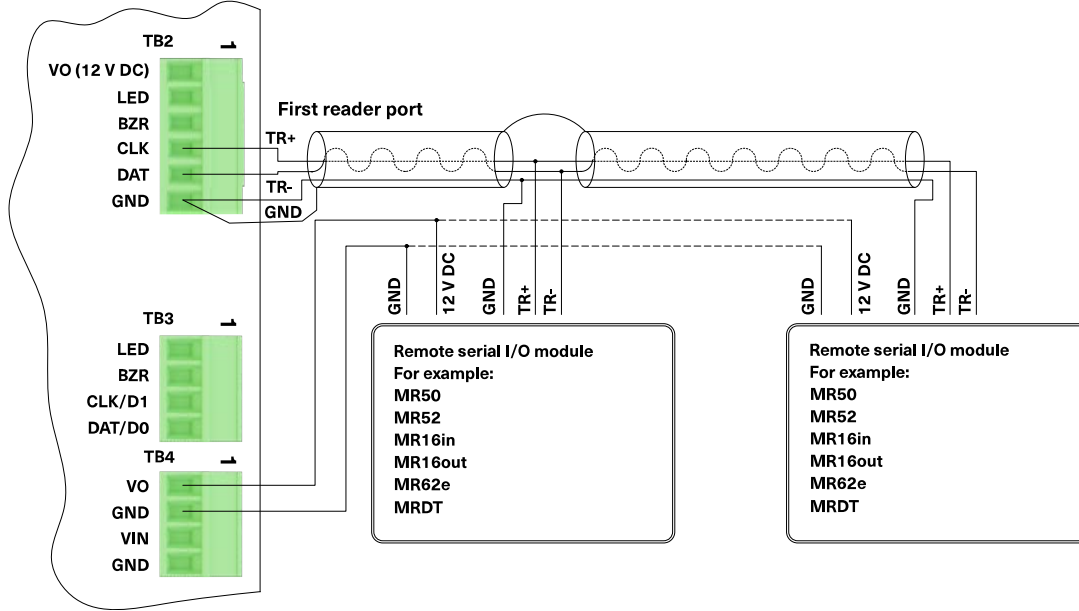

Reader port 1 - OSDP protocol devices (2-wire RS-485)

Refer to the appropriate OSDP device installation manual for address and baud rate settings. Do not terminate any of the devices on the RS-485 multi-drop communication bus. Each OSDP device must be configured with a unique communication address. A maximum of two OSDP devices can be connected to reader port 1. **Cable shield:** only ground one end.

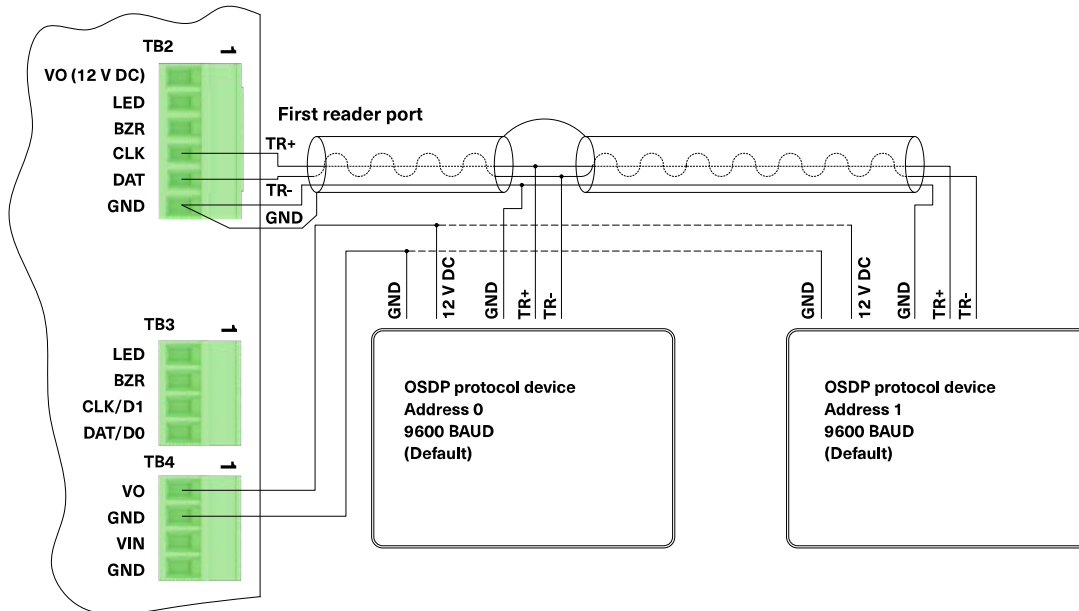

2.8 Communication wiring

The LP1501 controller communicates to the host via the on-board 10-BaseT/100Base-TX Ethernet interface.

2.9 Input circuit wiring

Typically, these inputs are used to monitor door position, request to exit, or alarm contacts. Input circuits can be configured as unsupervised or supervised. When unsupervised, reporting consists of only the open or closed states.

When configured as supervised, the input circuit will report not only open and closed, but also open circuit, shorted, grounded*, and foreign voltage*. A supervised input circuit requires two resistors are added to the circuit to facilitate proper reporting. The standard supervised circuit requires 1kΩ, 1% resistors and should be located as close to the sensor as possible. Custom end of line (EOL) resistances may be configured via the host software.

*Grounded and foreign voltage states are not a requirement of UL 294 and therefore not verified by UL.

The input circuit wiring configurations shown are supported but may not be typical:

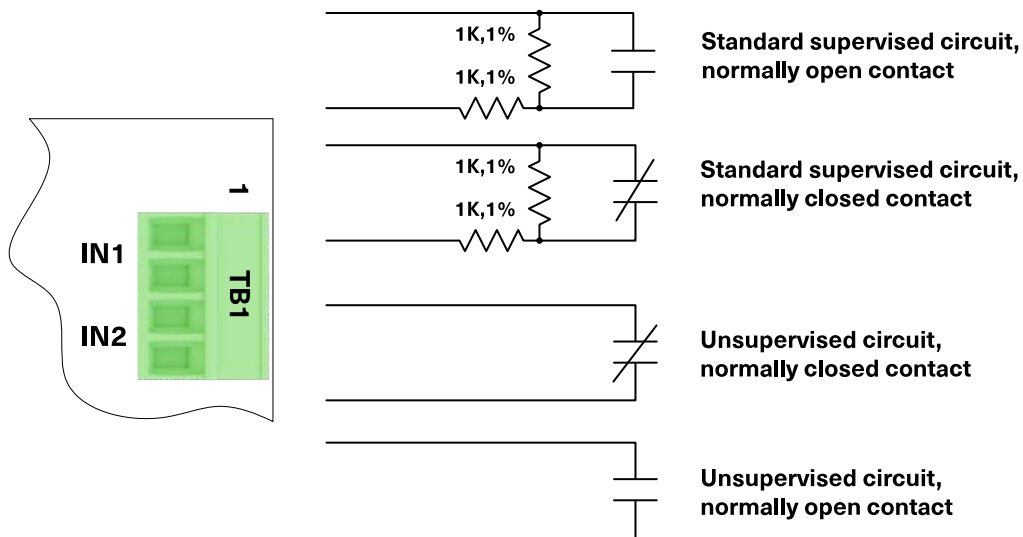

2.10 Relay circuit wiring

Two Form-C contact relays are provided for controlling door lock mechanisms or alarm signaling devices. The relay contacts are rated at 2 A @ 30 V DC, dry contact configuration. Each relay has a Common pole (**C**), a Normally Open pole (**NO**) and a Normally Closed pole (**NC**). When you are controlling the delivery of power to the door strike, the Normally Open and Common poles are used. When momentarily removing power to unlock the door, as with a mag lock, the Normally Closed and Common poles are used. Check with local building codes for proper egress door installation.

Door lock mechanisms can generate EMF feedback to the relay circuit that can cause damage and premature failure of the relay and affect the operation of the LP1501. It is recommended that either a diode or MOV (metal oxide varistor) is used to protect the relay. Wire should be of sufficient gauge to avoid voltage loss.



Caution: From the Auxiliary output, the LP1501 can provide 12 V DC power for external devices, provided that the maximum current is not exceeded. See **Specifications** for details. If a local power supply is used, it must be UL Listed Class 2 rated.

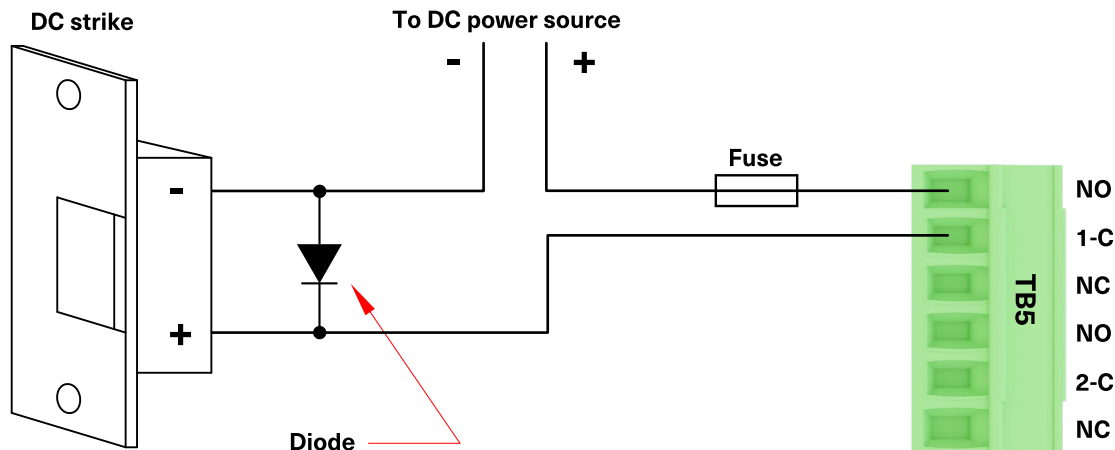

Diode selection

- Diode current rating: 1x strike current.
- Diode breakdown voltage: 4x strike voltage.
- For 12 V DC or 24 V DC strike, diode 1N4002 (100V/1A) typical.

2.11 Memory backup battery

The SRAM is backed up by a rechargeable battery when input power is removed. This battery should retain the data for a minimum of three days. If data in the SRAM is determined to be corrupt after power up, all data, including flash memory, is considered invalid and is erased. All configuration data must be re-downloaded.

Note: The initial charge of the battery may take up to 48 hours to be fully charged.

2.12 Status LEDs

2.12.1 Power-up

- 1.x firmware - All LEDs are off.
- 2.x firmware - NIC LED blinks and all other LEDs are off.

2.12.2 Initialization

The initialization process has several stages. Each stage is represented by a different LED pattern in the following sequence after power is applied or reset switch is pushed:

1.x firmware: -

- LED 1 is on for about 15 seconds.
- Then LEDs 2 through 7 are flashed once at the beginning of initialization.
- LEDs 5, 6 and 7 are turned on for approximately one second after the hardware initialization has completed, then the application code is initialized.

2.x firmware: -

- All LEDs are off for about 10 seconds.
- LED 2 is on for 25 seconds.
- LED 3 flashes slowly for 15 seconds.
- LED 3 flashes quickly for 1 second. LED 3 may continue flashing for an additional 60 seconds if the controller firmware is being updated.
- LED 1, LED 2, and LED 3 are off as the application starts.
- LED 4 is then on for 15 seconds indicating a successful initialization.

The amount of time the application takes to initialize depends on the size of the database, about one second without a card database. Each 10,000 cards will add about two seconds to the application initialization. When LEDs 1 through 4 flash at the same time, data is being read from or written to flash memory, do not cycle power when in this state. If the sequence stops or repeats, perform the bulk erase procedure, See **2.5 Bulk erase configuration memory**. If clearing the memory does not correct the initialization problem, contact Tech Support (TechSupport@Mercury-Security.com).

2.12.3 Running

After initialization is complete, the LEDs have the following meanings:

LED	Description
1	Off-Line / On-Line: Off-Line = 20% ON, On-Line = 80% ON
2	Host communication activity
3	Readers (combined): Clock/Data or D1/D0 Mode = Flashes when data is received, either Input. RS-485 Mode = Flashes when transmitting data F/2F Mode = Flashes when data/acknowledgment is received
4	Input IN1 Status: OFF = Inactive, ON = Active, Flash = Fault ¹
5	Input IN2 Status: OFF = Inactive, ON = Active, Flash = Fault ¹
6	Cabinet tamper
7	Reserved for future use

LED	Description
D9	Relay K1: ON = Energized
D10	Relay K2: ON = Energized
YEL	Ethernet Speed: OFF = 10 Mb/S, ON = 100 Mb/S
GRN	OFF = No link, ON = Good link, Flashing = Ethernet activity

1. If this input is defined, every three seconds the LED is pulsed to its opposite state for 0.1 seconds, otherwise, the LED is off.

2.13 IT security

Ensure that the LP1501 is installed securely. Create user accounts to the web configuration page using secure passwords.

Ensure all DIP switches are to be in the **OFF** position for the normal operating mode.

The LP1501 is shipped from the factory with a default login account, which is enabled when DIP 1 is moved from **OFF** to **ON** (See **2.3 DIP switches**). The default login user name (admin) and password (password) will be available for five minutes once the DIP switch is toggled. It is therefore important that at least one user account is defined, and the DIP switches are set to **OFF** before the LP1501 is commissioned.

Configuring the LP1501 with an IP address that is accessible from the public is **not** recommended.

The following options are available for enhanced network security:

- Disable SNMP.
- Zeroconf discovery.
- The web configuration module.
- Enable data encryption over the host communication port.

Section 03

Specifications

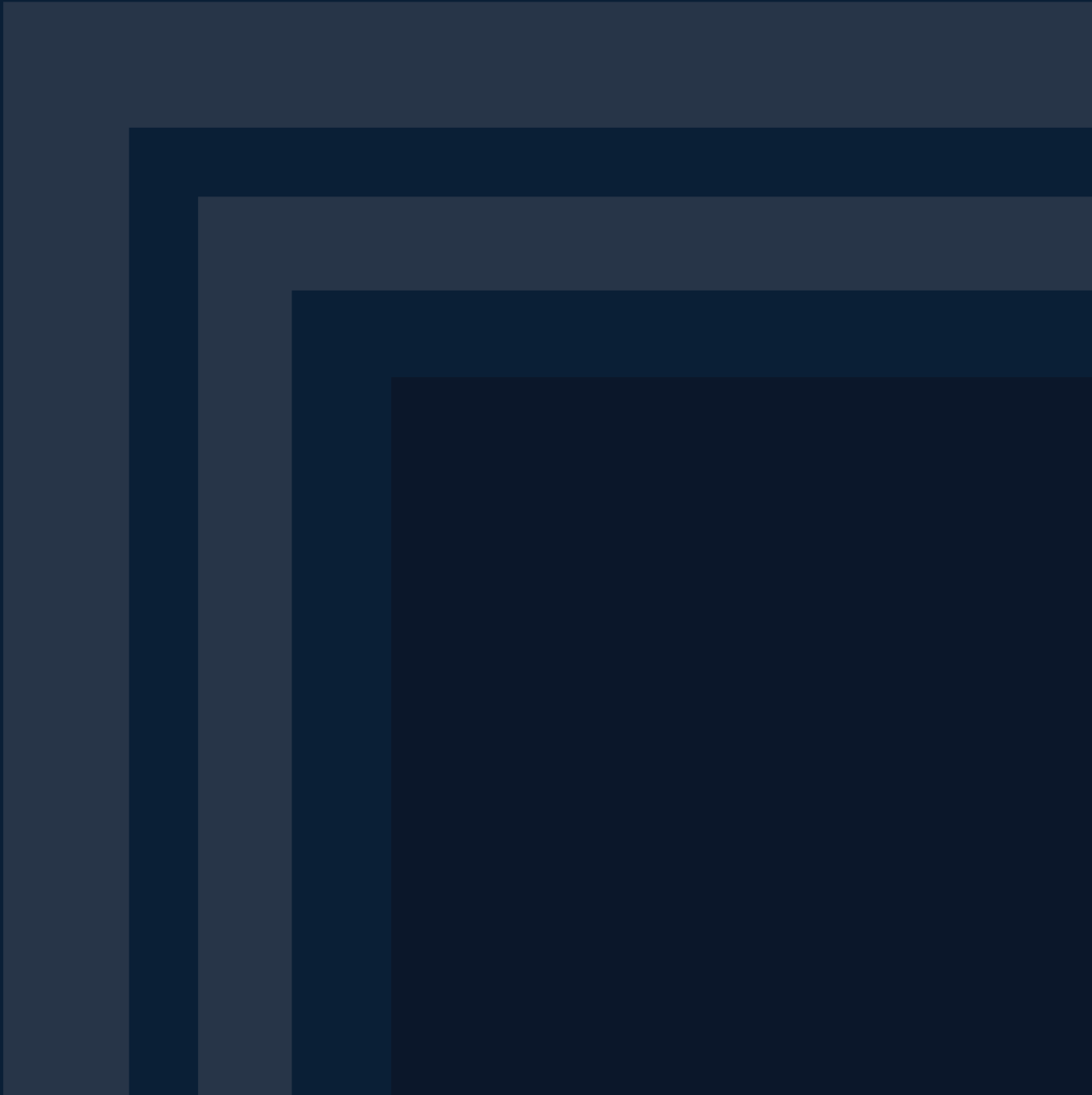

3.1 LP1501 controller specifications

The interface is for use in low voltage, Class 2 circuits only.

The installation of this device must comply with all local fire and electrical codes.

Primary power	PoE (12.95 W), compliant to IEEE 802.3af or PoE+ (25 W), compliant to IEEE 802.3at or 12 V DC \pm 10%, 1.8 A maximum
Power output	PoE: 12 V DC @ 625 mA including reader and auxiliary power output ¹
Power output	PoE+ or external 12 V DC: 12 V DC @ 1.25 A including reader and auxiliary power output ¹
Micro USB port	5 V DC maximum (deduct 270 mA from reader and auxiliary power output)

1. Excluding micro USB port



Caution: PoE power is to be supplied by a Listed ITE or Access Control System Unit (ALVY), power limited, PoE+ injector or PoE+ Ethernet switch providing 42.5 – 57 V DC, 25.5 W for maximum output.

SRAM backup battery	Rechargeable battery
microSD card	Format: microSD or microSDHC; 2GB to 8GB.
Host communication	Ethernet: 10-BaseT/100Base-TX and Micro-USB port (2.0) with optional adapter: pluggable model USB2-OTGE100
Inputs	Two unsupervised/supervised, programmable end of line resistors, 1k/1k Ω , 1%, ¼ watt standard One unsupervised input dedicated for cabinet tamper
Outputs	Two relays: Form-C contacts: 2 A @ 30 V DC, resistive
READER INTERFACE	
Power	12 V DC \pm 10%: PoE, PoE+ or local power supply, 300 mA maximum
Data inputs	Reader port 1: TTL compatible, F/2F or 2-wire RS-485 Reader port 2: TTL compatible or F/2F
LED output	TTL compatible, high > 3 V, low < 0.5 V, 5 mA source/sink maximum
Buzzer output	Open collector, 12 V DC open circuit maximum, 40 mA sink maximum
CABLE REQUIREMENTS	
Power	1 twisted pair, 18 AWG (when using local 12 V DC power supply)
Ethernet	CAT-5, minimum
Reader data (TTL)	6-conductor, 18 AWG, 500 feet (152 m) maximum
Reader data (F/2F)	4-conductor, 18 AWG, 500 feet (152 m) maximum
Reader data (RS-485)	1 twisted pair, shielded. 24 AWG, 120 Ω impedance, 2000 feet (610 m) maximum
Alarm input	1 twisted pair per input, 30 Ω maximum
Outputs	As required for the load

ENVIRONMENTAL	
Storage temperature	-55 to +85°C
Operating temperature	0 to +70°C
Humidity	5 to 95% RHNC
MECHANICAL	
Dimensions without bracket	5.5 inches (140 mm) W x 2.75 inches (70 mm) L x 0.96 inches (24 mm) H
Dimensions with bracket	5.5 inches (140 mm) W x 3.63 inches (92 mm) L x 1.33 inches (34 mm) H
Weight without bracket	3.6 oz. (103 g)
Weight with bracket	4.43 oz. (125.5 g)

UL294, 6th edition Performance Levels

Feature	Level
Standby Power	I
Endurance	IV
Line Security	I
Destructive Attack	I

These specifications are subject to change without notice.

3.2 Warranty

Mercury Security warrants the product is free from defects in material and workmanship under normal use and service with proper maintenance for one year from the date of factory shipment. Mercury Security assumes no responsibility for products damaged by improper handling or installation. This warranty is limited to the repair or replacement of the defective unit.

There are no expressed warranties other than set forth herein. Mercury Security does not make, nor intends, nor does it authorize any agent or representative to make any other warranties, or implied warranties, and expressly excludes and disclaims all implied warranties of merchantability or fitness for a particular purpose.

Returns must be accompanied by a Return Material Authorization (RMA) number obtained from customer service, and prepaid postage and insurance.

3.3 Liability

The Interface should only be used to control exits from areas where an alternative method for exit is available. This product is not intended for, nor is rated for operation in life-critical control applications. Mercury Security is not liable under any circumstances for loss or damage caused by or partially caused by the misapplication or malfunction of the product. Mercury Security's liability does not extend beyond the purchase price of the product.

3.4 Regulatory

This device complies with part 15 of the FCC Rules. Operation is subject to the following two conditions: (1) This device may not cause harmful interference, and (2) this device must accept any interference received, including interference that may cause undesired operation.

Section 04

Additional mounting information

4.1 Optional items

Sources for the optional items shown below:

- 3-gang stainless steel blank cover. Available from:
 - Leviton: part number 84033-40
 - Graybar: part number 88158404
- Magnetic switch set: G.R.I. part number: 505

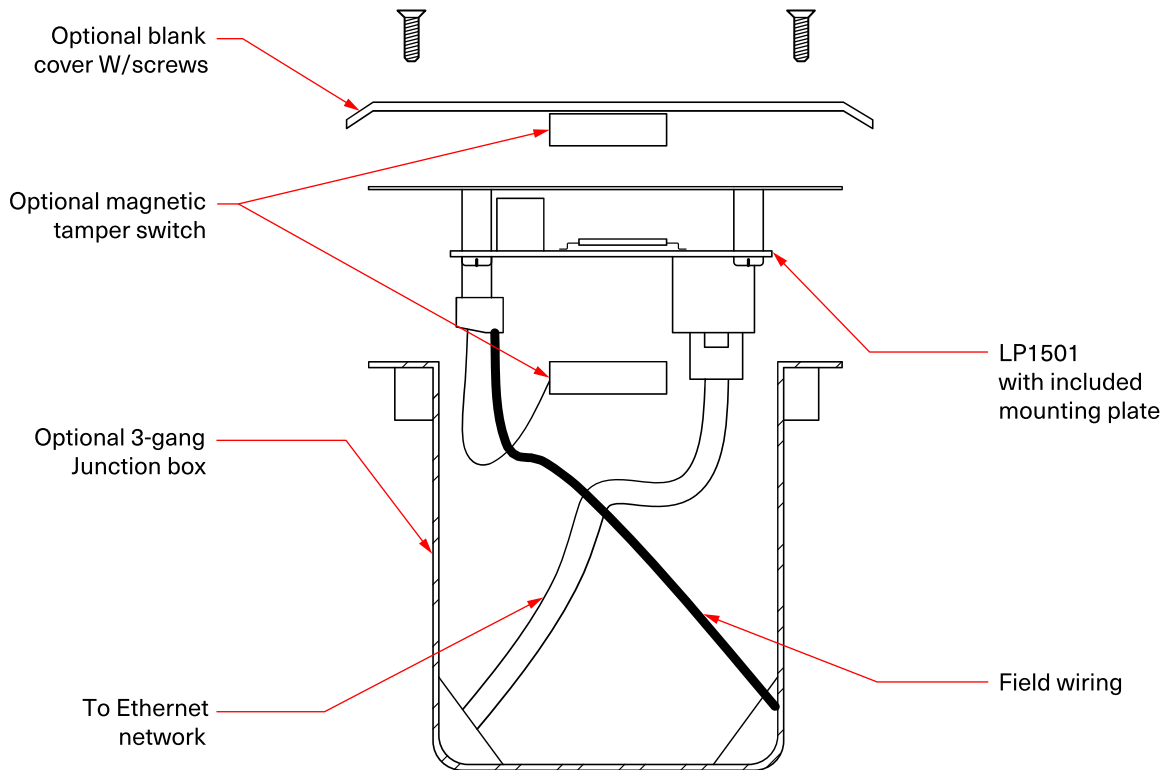

4.2 Mounting plate dimensions

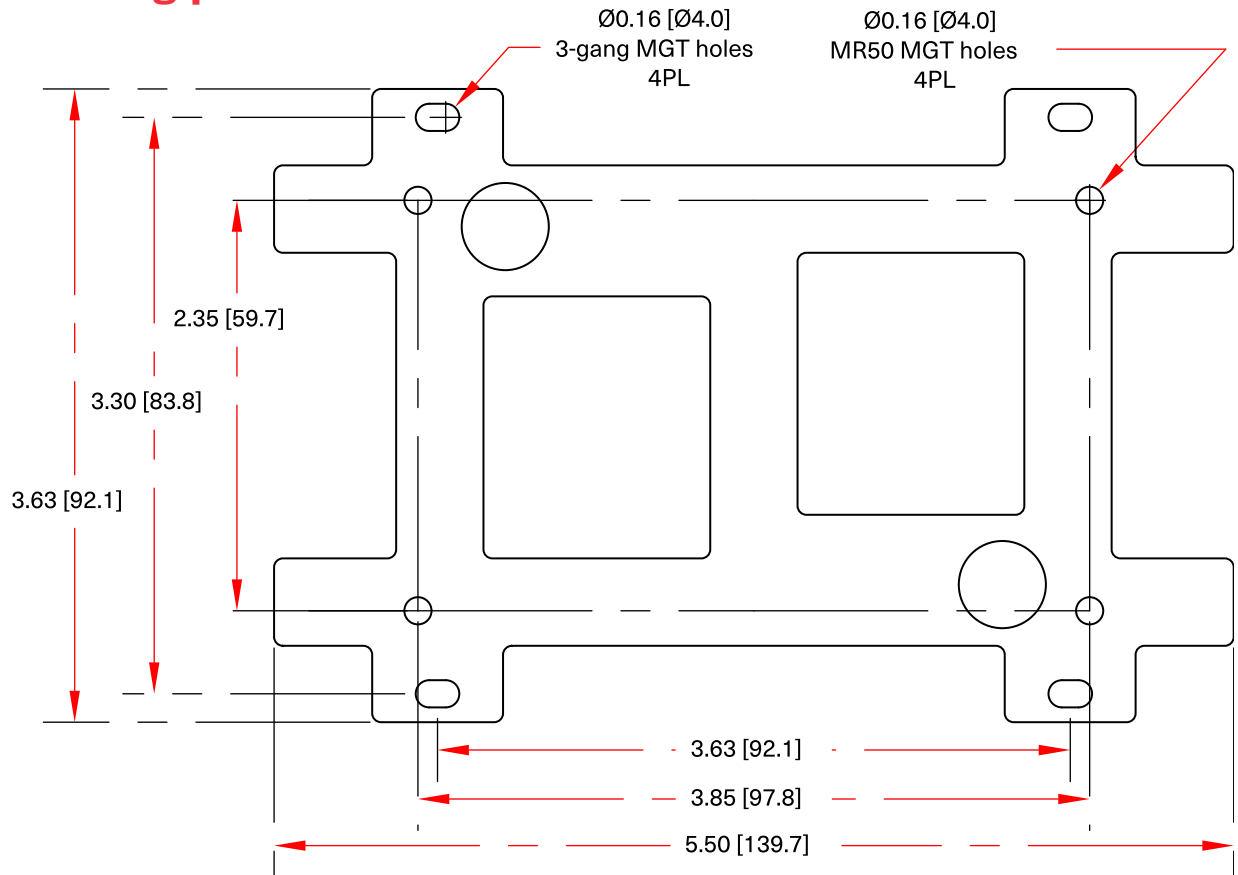

Revision history

Date	Description	Revision
August 2024	Updates to 2.12 Status LEDs	A.4
May 2024	Updated 2.5 Bulk erase configuration memory and 2.12 Status LEDs . Updated to new Mercury branding.	A.3
August 2022	New branding.	A.2
June 2021	Minor updates.	A.1
October 2020	Initial release.	A.0

